

**Technical Report
CMU/SEI-94-TR-5
ESC-TR-94-005**

Software Capability Evaluation (SCE) Version 2.0 Implementation Guide

CMM-Based Appraisal Project

February 1994

Technical Report
CMU/SEI-94-TR-5
ESC-TR-94-005
February 1994

Software Capability Evaluation (SCE) Version 2.0 Implementation Guide



CMM-Based Appraisal Project

Unlimited distribution subject to the copyright.

Software Engineering Institute
Carnegie Mellon University
Pittsburgh, Pennsylvania 15213

This report was prepared for the
SEI Joint Program Office
HQ ESC/AXS
5 Eglin Street
Hanscom AFB, MA 01731-2116

The ideas and findings in this report should not be construed as an official DoD position. It is published in the interest of scientific and technical information exchange.

FOR THE COMMANDER

(signature on file)

Thomas R. Miller, Lt Col, USAF
SEI Joint Program Office

This work is sponsored by the U.S. Department of Defense.

Copyright © 1994 by Carnegie Mellon University.

Permission to reproduce this document and to prepare derivative works from this document for internal use is granted, provided the copyright and "No Warranty" statements are included with all reproductions and derivative works.

Requests for permission to reproduce this document or to prepare derivative works of this document for external and commercial use should be addressed to the SEI Licensing Agent.

NO WARRANTY

THIS CARNEGIE MELLON UNIVERSITY AND SOFTWARE ENGINEERING INSTITUTE MATERIAL IS FURNISHED ON AN "AS-IS" BASIS. CARNEGIE MELLON UNIVERSITY MAKES NO WARRANTIES OF ANY KIND, EITHER EXPRESSED OR IMPLIED, AS TO ANY MATTER INCLUDING, BUT NOT LIMITED TO, WARRANTY OF FITNESS FOR PURPOSE OR MERCHANTABILITY, EXCLUSIVITY, OR RESULTS OBTAINED FROM USE OF THE MATERIAL. CARNEGIE MELLON UNIVERSITY DOES NOT MAKE ANY WARRANTY OF ANY KIND WITH RESPECT TO FREEDOM FROM PATENT, TRADEMARK, OR COPYRIGHT INFRINGEMENT.

This work was created in the performance of Federal Government Contract Number F19628-95-C-0003 with Carnegie Mellon University for the operation of the Software Engineering Institute, a federally funded research and development center. The Government of the United States has a royalty-free government-purpose license to use, duplicate, or disclose the work, in whole or in part and in any manner, and to have or permit others to do so, for government purposes pursuant to the copyright license under the clause at 52.227-7013.

This document is available through Research Access, Inc., 800 Vinial Street, Pittsburgh, PA 15212. Phone: 1-800-685-6510. FAX: (412) 321-2994. RAI also maintains a World Wide Web home page. The URL is <http://www.rai.com>

Copies of this document are available through the National Technical Information Service (NTIS). For information on ordering, please contact NTIS directly: National Technical Information Service, U.S. Department of Commerce, Springfield, VA 22161. Phone: (703) 487-4600.

This document is also available through the Defense Technical Information Center (DTIC). DTIC provides access to and transfer of scientific and technical information for DoD personnel, DoD contractors and potential contractors, and other U.S. Government agency personnel and their contractors. To obtain a copy, please contact DTIC directly: Defense Technical Information Center, Attn: FDRA, Cameron Station, Alexandria, VA 22304-6145. Phone: (703) 274-7633.

Use of any trademarks in this report is not intended in any way to infringe on the rights of the trademark holder.

Contents

Preface	vii
Abstract	vii
Purpose of This Document	vii
Acknowledgements	viii
Introduction	ix
Intended Audience for This Document	ix
Structure	ix
Part A SCE Overview	xi
Chapter 1 Introducing SCE	1-1
Background	1-1
Purpose of SCE	1-2
The Capability Maturity Model	1-3
The Model-Based Structure of the CMM	1-6
The Process Perspective vs. Traditional Product-Oriented Perspectives	1-12
Contractor Attributes Examined by SCE	1-16
The Results of an SCE	1-18
Comparing SPA and SCE	1-19
Facilitating SCE on Your Program	1-22
Chapter 2 Preparing to Use SCE	2-27
Determining SCE Use	2-27
Selecting the SCE Team	2-28
Training the SCE Team	2-32
Providing Directions to the Potential Offerors	2-35
Preparing and Conducting the Site Visit	2-36
Part B Using SCE in a Source Selection	B-39
Introduction	B-39
Chapter 3 Deciding to Use SCE	3-43
Criteria for Using SCE in a Source Selection	3-43
Benefits of Using SCE in a Source Selection	3-49
Cost of Using SCE	3-51

Chapter 4 Implementing SCE in a Source Selection	4-61
Scheduling SCE in a Source Selection	4-61
Using SCE Results in the Source Selection	4-66
Using SCE as a Specific Criterion For Award	4-67
Performance Risk Analysis Group (PRAG)	4-84
Chapter 5 Incorporating SCE into the Relevant Acquisition Documentation	5-85
Making the Commerce Business Daily Announcement	5-85
Placing SCE in the Source Selection Plan	5-87
Presenting SCE at the Pre-Proposal Conference	5-91
Placing SCE in the Request for Proposal	5-99
Placing SCE in the Evaluation Plan	5-108
Appendix A SCE Participants in a Source Selection	A-111
Appendix B Acronyms	B-117
Appendix C Bibliography	C-121
Appendix D SCE Implementation Checklist	D-125
Appendix E Templates	E-129
Appendix F Pre-Proposal Conference Slides	F-143

List of Figures

Figure 1-1	Capability Maturity Model Version 1.1	1-4
Figure 1-2	Capability Maturity Model Structure	1-7
Figure 1-3	Predicted Distribution of Performance as Organizational Process Maturity Increases	1-8
Figure 1-4	Level 2 and 3 Key Process Areas in the CMM	1-10
Figure 1-5	DoD-STD-2167A Activities	1-12
Figure 1-6	A Product Approach to Software Process	1-13
Figure 1-7	Sample of Contractor Attributes That Could Be Considered in a Software-Intensive Acquisition	1-17
Figure 1-8	Sample Key Process Area Finding	1-19
Figure 1-9	Differences Between Process Assessments and Capability Evaluations	1-20
Figure 1-10	Steps for Transferring the Evaluation Method into an Organization	1-23
Figure 1-11	SCE Implementation Checklist	1-24
Figure 2-1	SCE Preparation Timetable	2-28
Figure B-1	Source Selection Activities Affected By SCE	B-40
Figure 3-1	SCE Usage Decision Making Criteria	3-44
Figure 3-2	Estimated SCE Labor For One Source Selection	3-53
Figure 3-3	SCE Person-Loading Over Time	3-54
Figure 3-4	Example SCE Cost Summary (Training Plus Onsite)	3-56
Figure 3-5	Example SCE-Imposed Development Organization Costs	3-57
Figure 4-1	Sample SCE Schedule Leading Up To RFP Release	4-62
Figure 4-2	Sample SCE Schedule After RFP Release	4-65
Figure 4-3	Sample Set of Specific Criteria or Technical Items	4-68
Figure 4-4	Description of Colors	4-69
Figure 4-5	Description of Risks	4-70
Figure 4-6	Summary Findings From a Recent SCE	4-71
Figure 4-7	Detailed Findings	4-73
Figure 4-8	Detailed Findings (continued)	4-74
Figure 4-9	Findings Incorporated Into a Point For Negotiation (PFN)	4-75

Figure 4-10	Findings Incorporated in Item Summary	4-78
Figure 4-11	Findings Incorporated in Item Summary (continued)	4-79
Figure 4-12	Findings Output From the Evaluation Standard	4-81
Figure 4-13	Technical Area Summary	4-83
Figure 5-1	Sample CBD Announcement	5-86
Figure 5-2	SCE as a Screening Criterion in the SSP	5-88
Figure 5-3	SCE as a Specific Criterion For The SSP	5-89
Figure 5-4	SCE as part of the PRAG for SSP	5-90
Figure 5-5	Pre-proposal Conference Title and Agenda Slides	5-92
Figure 5-6	Pre-proposal Conference SCE Method Slides	5-93
Figure 5-7	Pre-proposal Conference Documentation Slide	5-94
Figure 5-8	Pre-proposal Conference Site Visit Schedule Slide	5-96
Figure 5-9	Pre-proposal Conference CMM Slide	5-97
Figure 5-10	Pre-Proposal Conference Sample Findings Slides	5-98
Figure 5-11	General RFP Language To Include SCE (RFP Section M)	5-100
Figure 5-12	Instructions For Completing Assessment Recording Forms	5-103
Figure 5-13	Instructions For Completing Project Profiles	5-104
Figure 5-14	Instructions For Submitting the Software Process Improvement Plan (SPIP)	5-105
Figure 5-15	Instructions For Site Visit Coordination	5-106
Figure 5-16	Streamlined SCE Evaluation Standard	5-109
Figure A-1	Sample Source Selection Organization	A-111
Figure E-1	Sample CBD Announcement	E-129
Figure E-2	SCE as a Screening Criterion in the SSP	E-129
Figure E-3	SCE as a Specific Criterion For The SSP	E-130
Figure E-4	SCE as part of the PRAG for SSP	E-131
Figure E-5	Pre-proposal Conference Title and Agenda Slides	E-131
Figure E-6	Pre-proposal Conference SCE Method Slides	E-132
Figure E-7	Pre-proposal Conference Documentation Slide	E-133
Figure E-8	Pre-proposal Conference Site Visit Schedule Slide	E-134
Figure E-9	Pre-proposal Conference CMM Slide	E-135
Figure E-10	Pre-Proposal Conference Sample Findings Slides	E-136
Figure E-11	General RFP Language To Include SCE (RFP Section M)	E-137
Figure E-12	Instructions For Completing Assessment Recording Forms	E-138

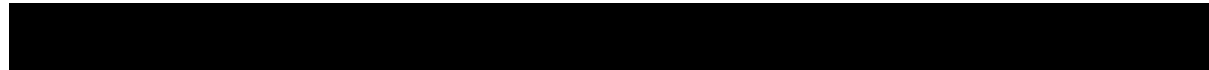

Figure E-13	Instructions For Completing Project Profiles	E-139
Figure E-14	Instructions For Submitting the Software Process Improvement Plan (SPIP)	E-139
Figure E-15	Instructions For Site Visit Coordination	E-140
Figure E-16	Streamlined SCE Evaluation Standard	E-141

Preface

This report documents the SCE implementation procedures developed for the Electronic Systems Center (ESC), Hanscom Air Force Base. The information contained in this report was developed before the release of the *Software Capability Evaluation Version 2.0 Method Description* [SCE 94].

Inconsistencies should be checked against that document which takes precedence in matters of SCE methodology.

Abstract

Software Capability Evaluation (SCE) offers a means to evaluate an organization's software process capability—that is, how well an organization manages the process it uses to create software. SCE provides a way to compare a development organization's software process against a predefined standard. This document is an implementation guide: it is intended as a set of practical information which program managers can use to guide them through the process of using SCE in an acquisition.

Purpose of This Document

The Software Engineering Institute's (SEI) Software Capability Evaluation Method, as introduced in this guide, offers a means to help acquisition managers

- Identify program risk by evaluating software process capability in source selection.
- Manage program risk by motivating contractors to improve their software development processes without forcing compliance to specific practices.

This guide can be used to implement the SCE Method in order to achieve the goals above. It provides specific information necessary to orchestrate SCE use during the source selection process. Specifically, this guide

- Provides guidance on how to use the SCE method as a tool to identify software risk during a source selection.
- Provides standardized SCE implementation guidance which is documented, available for review and comment, and periodically modified as experience is gained with its use.
- Provides information which will help acquisition organizations develop appropriate policies, implementing instructions, and guidelines to use SCE in source selection and institutionalize SCE as a routine practice.
- Supplements, but *does not* replace, team training for evaluating the software process capability of contractors.

Acknowledgements

The Software Capability Evaluation Method was originally developed by Watts Humphrey and William Sweet of the SEI, with contributions from R. K. Edwards, G. R. LaCroix, M. F. Owens and H. P. Schultz of the MITRE Corporation.

This document was written by a team consisting of Rick Barbour, Paul Byrnes, and Bob Lang.

This document is based largely on the previous work that led to the *SCE Implementation Guide Version 1.0*. Thanks are again offered to all of the folks who contributed to developing, writing and reviewing that document. Many reviewers have contributed to the development and revision of this document; their valuable insights added a great deal to the quality of the finished product.

Introduction

Intended Audience for This Document

The primary audience for this document is program office personnel responsible for the software component of an acquisition. The guide assumes that the program manager will be delegated the responsibility for determining appropriate SCE usage, developing plans for implementing SCE, and carrying out the SCE plan. Program managers should be familiar with the material contained in Part A of the guide, as a minimum.

Although this document provides examples and models of SCE use in source selections and talks to some specific details of source selection, it is a guide and is not intended to replace the use of organizational regulations on source selection. In order to work any source selection successfully it is imperative to work with the local procurement and legal staff as well as the source selection and specific acquisition regulations, which take precedence over this document.

In cases where SCE is being used in a source selection, source selection personnel should be familiar with Parts A and B of this guide. Part A provides an overview of the SCE Method and its uses. Part B discusses the details of incorporating SCE into source selections of specific acquisitions.

Structure

Part A of this guide provides an introduction to SCE that all readers should understand. It provides an overview of SCE's technical basis along with a high level view of the mechanics of executing an SCE in an acquisition and a discussion of the underlying Capability Maturity Model (CMM). The emphasis in Part A is on providing the basic understanding of the SCE Method necessary for a user to focus on the source selection use of the SCE Method.

Part B focuses on how to implement SCE in a source selection. This portion of the guide introduces the key activities and is followed by specific guidance on how to use the method and

the documentation needed to execute recommended approaches. The examples included are modified instances of an implementation of SCE. There may be other approaches that are equally valid and useful. Some audiences may only be concerned with a subset of the information about the SCE method contained in this guide; consequently, the material has been organized so that different audiences can focus attention on specific pieces.

Part A SCE Overview

Chapter 1 Introducing SCE

This part of the document introduces the Software Capability Evaluation (SCE) Method and relates it to the SEI Capability Maturity Model (CMM). Chapter 1 describes what SCE is and Chapter 2 discusses the execution of SCE on an acquisition.

Background

Early attempts at improving the acquisition process began with a memorandum published by Deputy Secretary of Defense Frank C. Carlucci III in 1981. Initiative 11 of this memorandum [Carlucci 81] required the Department of Defense (DoD) to increase the visibility of technical risk in the budgets of acquisition programs for weapon systems. In 1986, the United States General Accounting Office (GAO) released a report titled “Technical Risk Assessment—The Status of Current DoD Efforts” [GAO 86], which examined the methodology used for assessing technical risks within 25 program offices. The deficiencies found by GAO prompted development of various risk assessment, evaluation, and management publications, including the Defense Systems Management College (DSMC) guide, “Risk Management Concepts and Guidance.” [Deep], DoD organizations launched further initiatives to improve their risk assessment capability. One such initiative resulted in development of the SCE Method.

The SCE Method complements earlier work by extending technical risk assessment to include the software process. It establishes software process capability as a criterion for source selection by providing an orderly way to compare offerors’ software capability against a predefined process maturity model. SCE should be used to augment other software risk assessment techniques currently used in source selection and contract monitoring.

The SCE Method was conceived and developed by the SEI and the MITRE Corporation in 1987, at the request of the Air Force. It was designed to help program managers determine the software process capability of a contractor at one organizational site (facility or location).

SCE provides a snapshot of a contractor's past process implementation, current process activities, and future process potential. The SCE site visit is an in-plant review conducted by four to six personnel over a three day period at a contractor's facility. The output from an SCE site visit is a set of findings; of strengths, weaknesses, and improvement activities measured against the CMM. The CMM is the technical basis for reporting the findings of the SCE Method. The CMM is described in the following two documents:

- *Capability Maturity Model for Software, Version 1.1* [Paulk 93a]
- *Key Practices of the Capability Maturity Model, Version 1.1* [Paulk 93b].

Purpose of SCE

The SCE team identifies an offeror's strengths, weaknesses, and any improvement activities in relation to the CMM and the sponsoring organization's objectives. The findings of the SCE team are incorporated into the source selection sponsoring organization's technical/management team for incorporation into acquisition decisions. The SCE team assimilates data on various project practices and from these creates an overall picture of the organization's software process capability relative to the CMM.

Cost, schedule, and performance are high priorities for the program manager. A basic tenet of the SCE Method and CMM is that the more mature the contractor's software processes are, the more likely it is that the contractor can meet predicted cost, schedule, and performance targets. Because SCE evaluates an organization's software process, acquisition organizations gain insight into this key area, an area

traditionally not evaluated in the past. Note that SCE supplements the use of other considerations such as application domain expertise, past performance, and organizational capacity in acquisition decisions.

The Capability Maturity Model

Basic Concepts

The CMM is based on the premise that the quality of a product stems in large part from the quality of the process used to create it. To improve product quality in the Total Quality Management (TQM) sense, the process used for developing the products should be defined, understood, measured, and progressively improved. As process quality increases, management also has greater insight, understanding, and control of risks. Concepts of process and quality management are applied to building and maintaining software products by using the CMM in conjunction with the SCE Method.

Capability Maturity Model for Software [Paulk 93a] describes the framework of the CMM (v1.1). The CMM organizes common, proven software development practices into a structured framework that can be used to focus quality improvement efforts. Teams use the SCE Method v2.0 to evaluate contractors against the CMM v1.1 (as of October 1993). Previously, SCE teams were trained using the maturity framework as described in *Characterizing the Software Process: A Maturity Framework* [Humphrey 87a] and *A Method for Assessing the Software Engineering Capability of Contractors* [Humphrey 87b], referred to in this document as CMM version 0.

The Maturity Model and Software Quality Improvement

The maturity model discussed in *Capability Maturity Model For Software* [Paulk 93] consists of five maturity levels with key process areas (KPA) assigned to each. Figure 1-1 shows the name and number of each level in the left column. Level one is the lowest; five is the highest. The general characteristics of an organization functioning at a particular maturity level are

listed in the middle column, and the KPAs associated with each level of the maturity model are on the right. This maturity model is the foundation upon which the CMM was built. A reading of *Key Practices of the Capability Maturity Model* [Paulk 93b] will reveal an expansion of the CMM into more practical aspects of software engineering.

Level	Characteristic	Key Process Area
Optimizing (5)	<ul style="list-style-type: none"> Continuous process improvement capability 	<ul style="list-style-type: none"> Process change management Technology innovation Defect prevention
Managed (4)	<ul style="list-style-type: none"> Product quality planning and tracking of measured software process 	<ul style="list-style-type: none"> Software Quality Management Quantitative Process Management
Defined (3)	<ul style="list-style-type: none"> Life cycle process defined and institutionalized to provide product quality control 	<ul style="list-style-type: none"> Peer Reviews Intergroup coordination Software product engineering Integrated software management Training program Organization process definition Organization process focus
Repeatable (2)	<ul style="list-style-type: none"> Management oversight and tracking of project Stable planning 	<ul style="list-style-type: none"> Software Configuration Management Software quality assurance Software subcontract management Software project tracking and oversight Software project planning Requirements management
Initial (1)	<ul style="list-style-type: none"> Ad hoc (unpredictable, chaotic) 	

Figure 1-1 Capability Maturity Model Version 1.1

The KPAs are “stepping stones” for moving to higher levels—that is, a company must be proficient in the KPAs within a maturity level in order to move up to the next level. For instance, without a stable and repeatable software project planning system, investments in a formal definition of the organization’s technical software process aren’t likely to overcome the limitations imposed by poor software project planning. The model is organized with basic project

management practices at the lowest levels, and the more sophisticated practices supporting product development at the higher levels. While moving up to higher levels, a company must improve as well as maintain proficiency in the KPAs of the lower levels.

The model is structured to demonstrate that the greatest benefit from quantitative measures of the process come when all of the KPAs through the defined level are successfully implemented first. The CMM in effect provides a step ladder that management can use to prioritize scarce resources towards the greatest long term benefit to the organization. With this structure it is predicted that an organization can better understand the processes implemented throughout the company and design an improvement plan with better chances of success. Consequently, this understanding leads to more efficient and effective investments in people, process, and technology which are the key elements of a sound organizational improvement program.

A General
Description Of
Organizations At
Each Maturity Level

Five basic levels of process maturity have been defined in the model to describe the progression from an ad hoc software process to one that is under statistical control and can act as a foundation for continuous process improvement.

Level 1 (initial): Projects can be characterized as routinely being late and exceeding the planned budget.

Level 2 (repeatable): The organization installs basic management controls and generally learns to manage its costs and schedules while building similar software products. The focus is on the product, and the management system is largely reactive.

Level 3 (defined): The process is understood and explicitly defined. Here, the organization introduces a structured framework for software development and establishes dedicated process improvement resources.

Level 4 (managed): The processes are quantified, measured, and reasonably well controlled. Data is available to establish improvement priorities and to support tool and technology investment. In statistical process control terms, special causes of process variation are under control.

Level 5 (optimizing): The common causes behind process variations are systematically addressed, and process data is used to improve the process in response to new and evolving issues and capabilities. The organization focuses on continuous improvement guided by process data.

The Model-Based
Structure of the
CMM

Figure 1-2 shows how the various aspects of the CMM relate to one another. Maturity levels are the highest abstraction, while the key practices are the most detailed portion of the model. The key indicators, and hence the maturity questionnaire, are derived from the key practices.

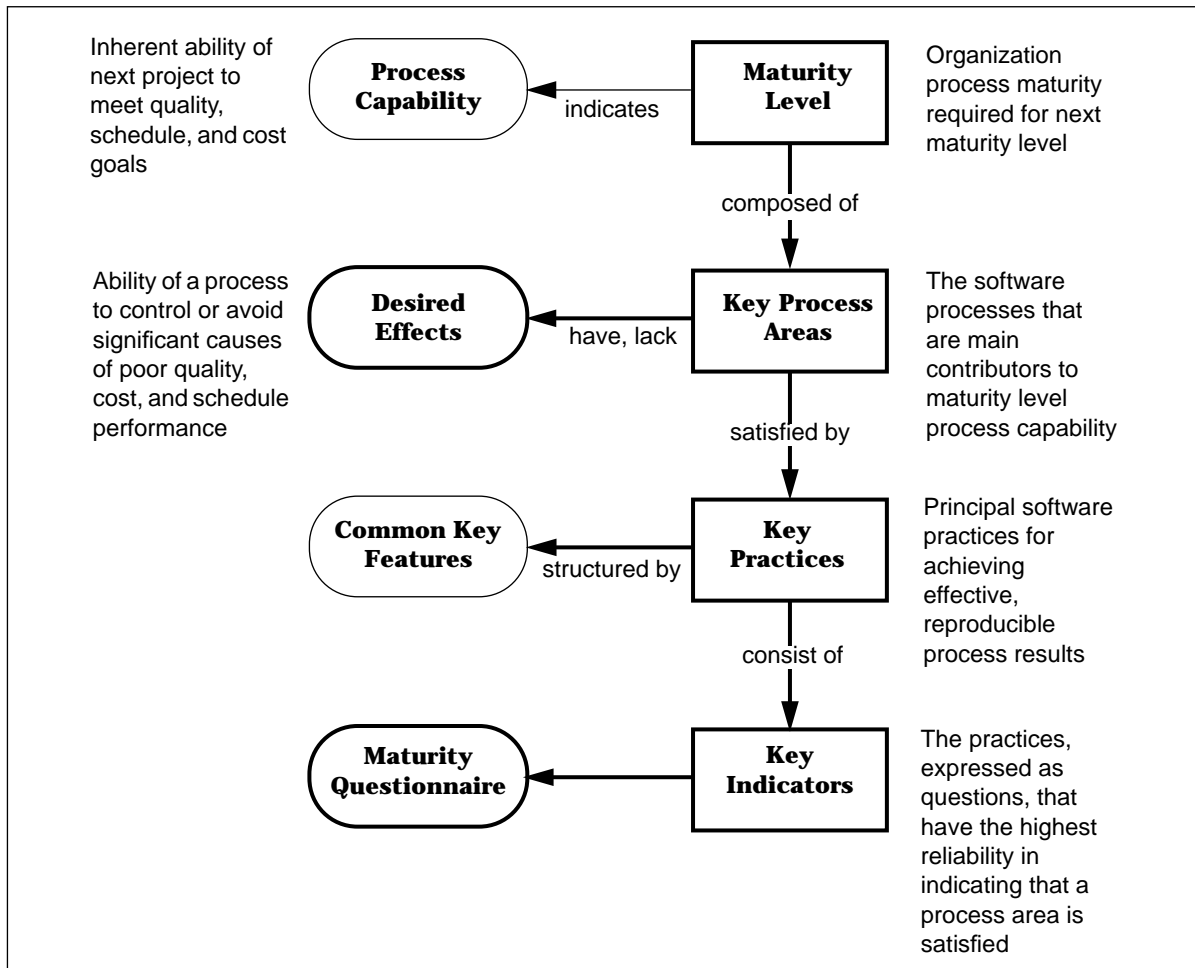

Figure 1-2 Capability Maturity Model Structure

Effects of Increasing Maturity On Program Predictability

Another important premise of the CMM is that increasing process maturity leads to reduced variance in the performance of the software process and increased software process capability, as illustrated in Figure 1-3. Organizations at the initial maturity level will miss the target performance on most of their projects. Occasionally, a strong manager may drive one project in a Level 1 organization to a higher level of process capability, but that capability is not present throughout the organization. As organizations reach higher

maturity levels, there is a more effective infrastructure in place to drive the process capability applied on the next acquisition to achieve program goals.

With increasing maturity:

- accuracy increases
- variance reduces
- target improves

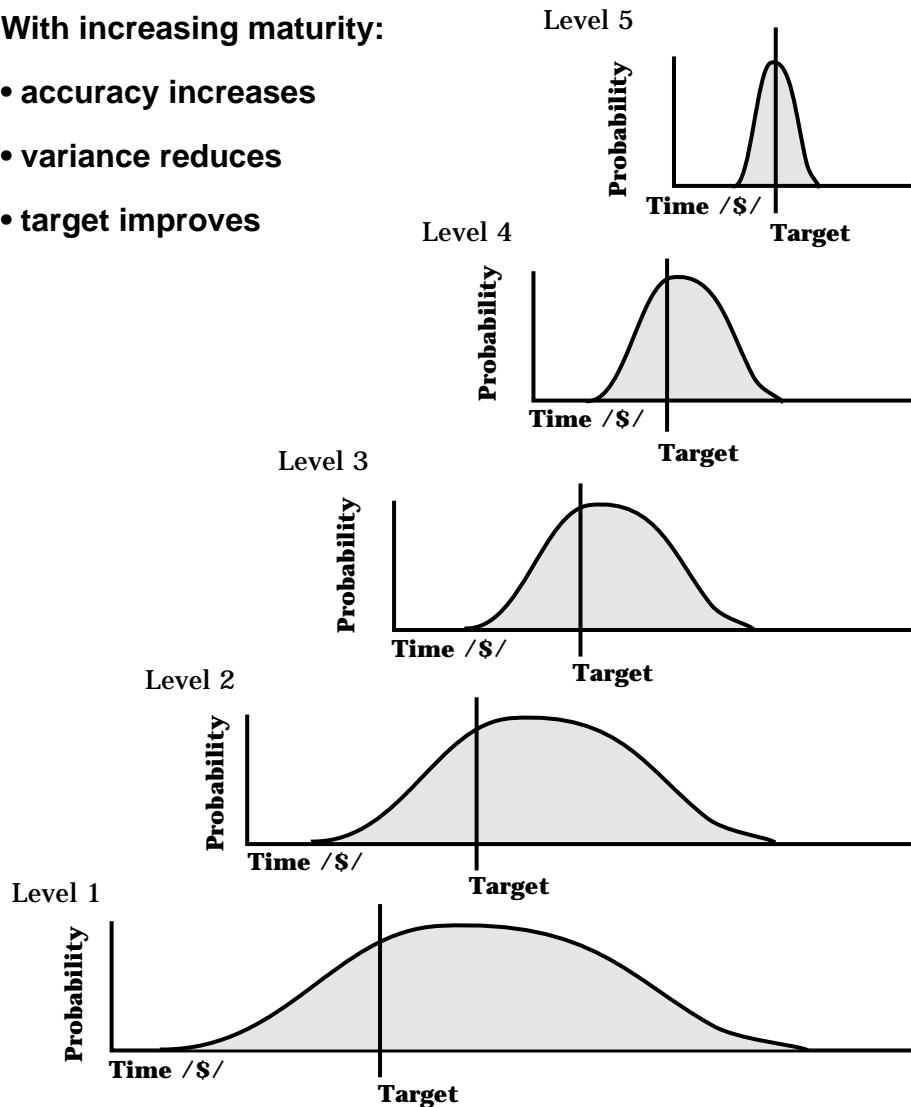

Figure 1-3 Predicted Distribution of Performance as Organizational Process Maturity Increases

The defined level is the starting point from which to achieve statistical process control, which enables an organization to understand where and how the quality and productivity of a process can be continuously improved. Level 5 (optimizing) is

the level at which data is available to tune the process itself. The optimizing level is not intended to be an end-point, however, and should properly be viewed as a beginning of orderly and managed process improvement. The evolutionary journey from Level 1 to Level 5 can then be seen as building the organizational capability to make sustained and continuous improvement.

Software Process
Areas Covered in
the CMM

The SCE team determines what process activities are actually implemented within a development organization. Figure 1-4 depicts the separate software process areas defined in the CMM. The shaded boxes reflect areas covered by the CMM key process areas (KPA's).

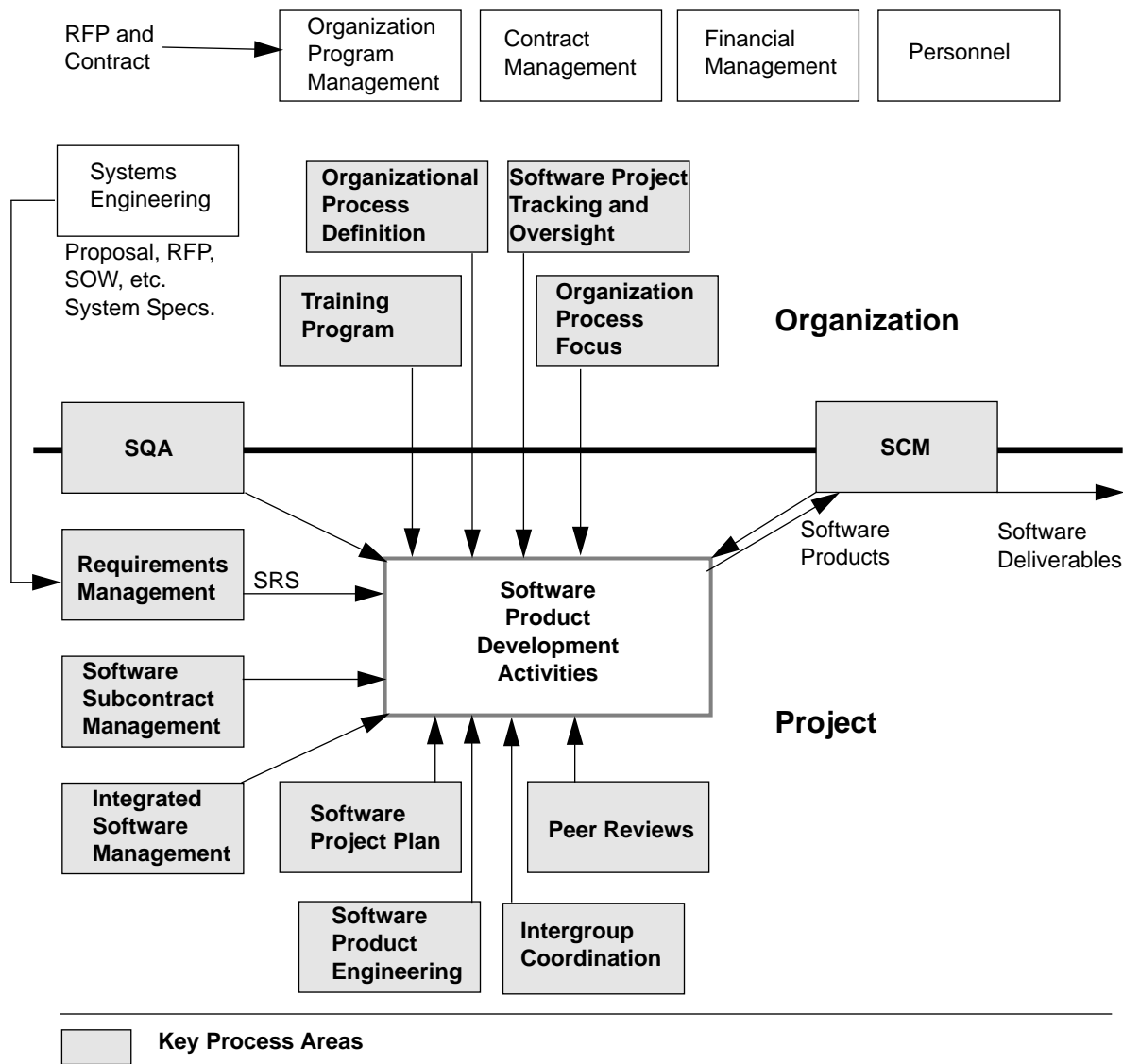

Figure 1-4 Level 2 and 3 Key Process Areas in the CMM

Figure 1-4 illustrates a key difference between traditional views of software development process and the CMM. The activities within the dashed rectangle are essentially product building activities (e.g. Requirements Analysis, Design, Testing). Traditionally software product development has

focused on product building activities such as these. But this traditional approach ignores many key *process* activities (shown as shaded boxes) which are crucial to successful product building.

The SCE team examines not only the part of the software development process that typically shows up in the Software Development Plan (dashed rectangle depicted as software product development activities), but also the forces acting on the process and the relationships between the forces.

The Process Perspective vs. Traditional Product-Oriented Perspectives

Figure 1-5 shows the DoD-STD-2167A software development activities associated with the typical Engineering Manufacturing Development (EMD) program. Most programs throughout the system acquisition lifecycle are managed by a lifecycle development model that is composed of these activities.

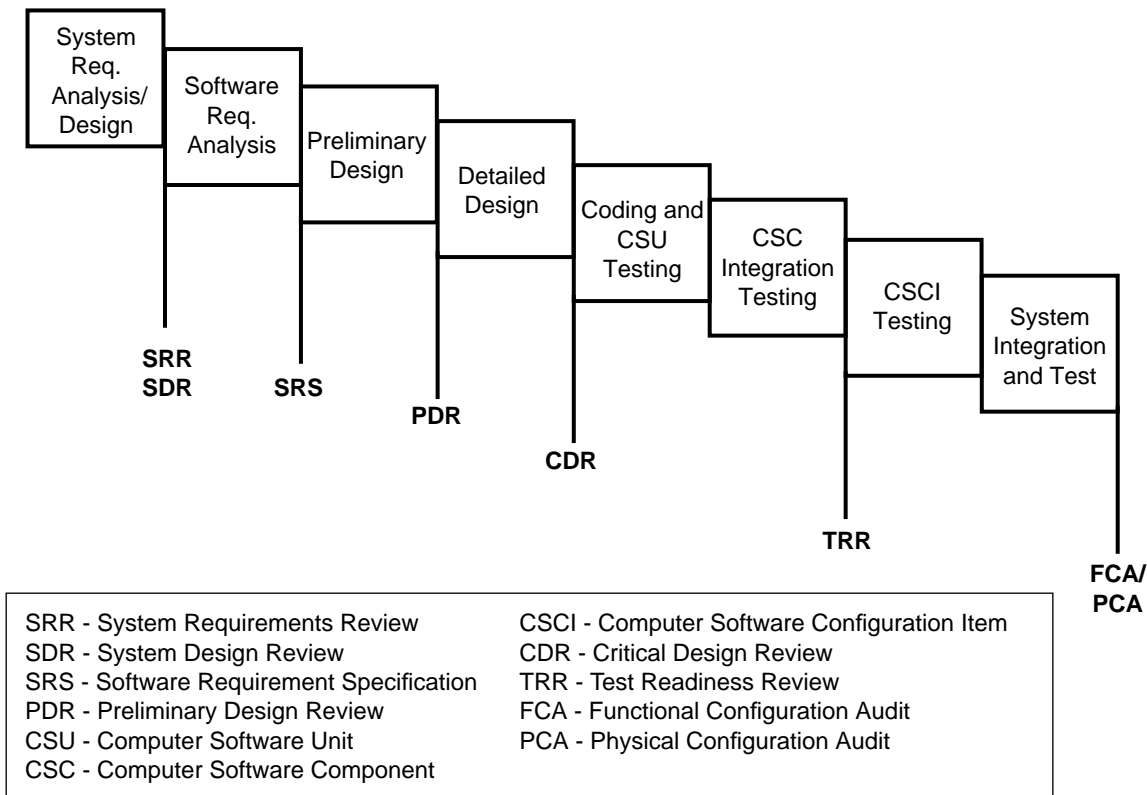

Figure 1-5 DoD-STD-2167A Activities

Each of these development steps are made more effective by support from the KPAs in the CMM. Historically, government programs have focused on the development of software products without regarding the supporting processes as equally important. DoD-STD-2167A reflects this bias toward product delivery. The KPAs provide a supporting process environment in which the organization can make effective decisions regarding the deliverables shown in Figure 1-5. Thus a focus on KPAs balances the

historical product orientation with a process focus that is critical in predicting contractor performance and measuring product development expertise.

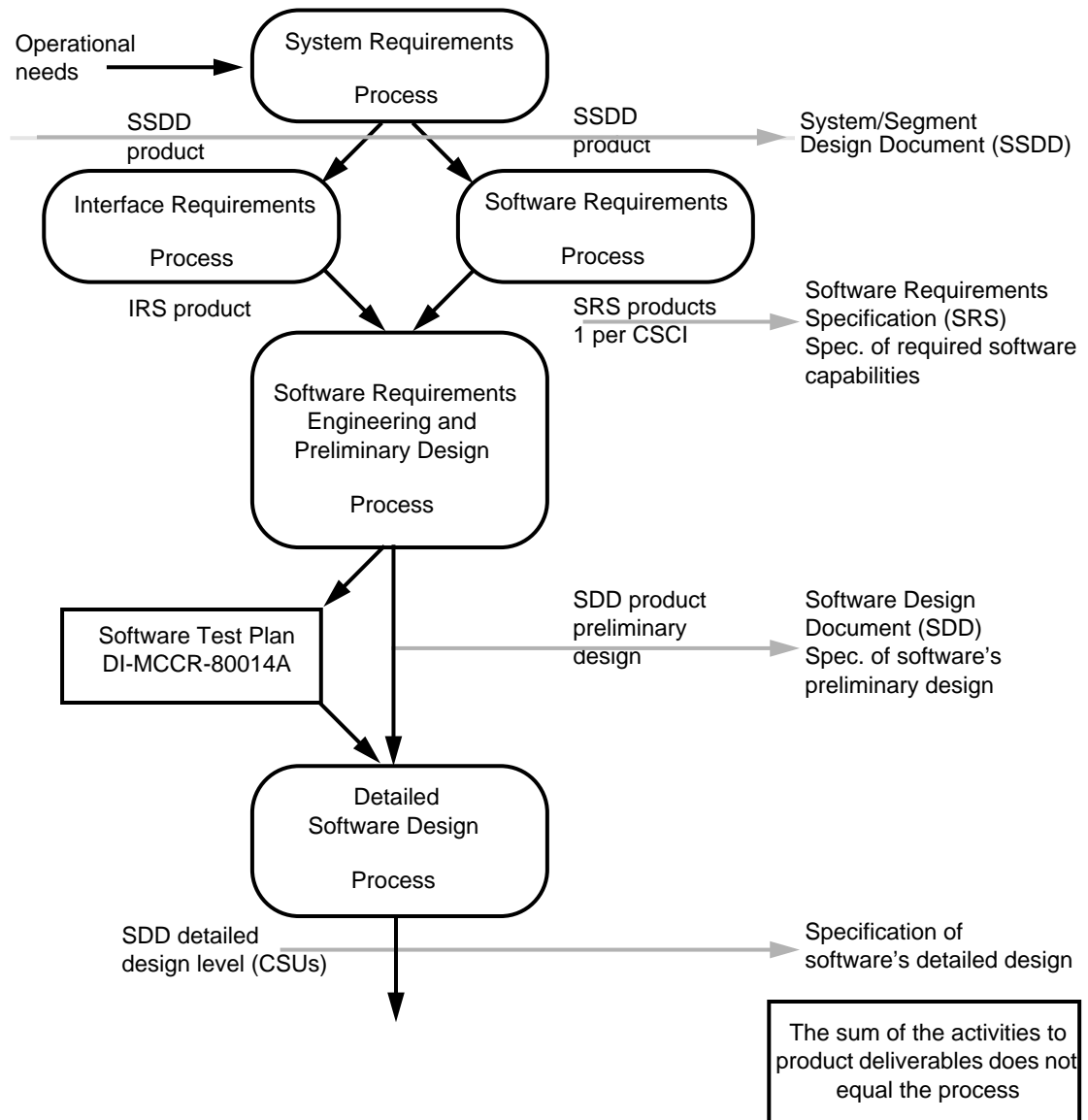

Figure 1-6 A Product Approach to Software Process

Figure 1-6 graphically depicts a product documentation approach to software process often adopted by acquisition and contractor management. One common problem is that people often equate the organization's software process to the

creation of output products during each of the steps shown above. The actual software development process implemented in an organization contains many more activities than the steps directly related to the product building parts of the process. Documents defining specific intermediate products are not the process, but are in fact artifacts of the process which is implemented in an organization. A successful program manager will focus on process (as well as product) as a predictor of future performance of the development of the product he or she is tasked to acquire.

Another problem with the product view of software process shown in Figure 1-6 is the fact that products built by a software development organization are often overcome by technological or environmental obsolescence very quickly. In this acquisition environment, it is difficult to estimate accurately new program risks by investigating existing systems because the existing systems may be obsolete.

New program risk assessment is difficult because one cannot assume an organization has the ability to take on a more technologically advanced or larger project, make effective use of new technology, or address changes in the threat or development environment based on past project success alone. This is because software system requirements are rarely the same from project to project. New requirements and advances in technology inevitably mean that old ways of conducting business will be inadequate. Thus it is essential for organizations to focus on the processes that support the product development activities.

Using prior data to evaluate parameters of the new system assumes the new system is “precedented,” meaning it is similar to systems previously built. According to the Air Force Studies Board [AFSB 89], a precededented system meets three criteria:

1. A stable set of software requirements exists that is not substantially different from that of a previous system.

2. The digital system architecture and software design that will satisfy the given requirements are known.
3. The contractor's system engineering and software teams communicate effectively with each other and have prior experience in developing a similar system.

According to the AFSB, the majority of USAF systems (and by implication all modern complex weapon systems) can be considered unprecedented in that major portions of the software development do not meet at least one of the criteria above.

The ability to address these issues is as much dependent on the organization's software process capability as it is on past product building successes. Risk abatement can be better achieved by evaluating software process capability in addition to using traditional product-specific methods. Institutionalization of the key software practices provides another indicator of how the organization is likely to address technological challenges and manage risks.

A program manager must wrestle with product-oriented questions, but answers to these questions will not address many of the software process-specific risks in acquisitions. Typical capacity reviews derive current capability from past performance, and are used to answer many product-oriented questions. The SCE Method adds value to the typical capacity review because it measures a subset of software process attributes that are believed to indicate organizational ability to successfully develop the product to be acquired—in other words, to take on future challenges, rather than past efforts.

An example which illustrates the difference between a capacity review and an SCE is in the training area. Assume a new procurement calls for 500 KSLOC in Ada, and 50 Ada programmers are expected over the life of the EMD phase. In a capacity review, the government team is primarily concerned with whether the contractor has enough experienced Ada people on hand to perform the work. In an SCE, the emphasis is not on specific people, but on the process

the contractor uses for training—in this case, the process and plans for training the Ada programmers if not enough are available to work on the project.

Both process and product perspectives are important to the program manager. The contractor's software process is by no means a program manager's only concern. But if the program manager focuses on process capability in addition to traditional product-oriented concerns, risk areas can be identified up front, and quality problems which may occur on the program due to those risks can be proactively managed and prevented.

**Contractor
Attributes
Examined by
SCE**

The findings from an SCE—strengths, weaknesses and improvement activities relative to the CMM—can influence the source selection decision or contribute to the future direction of an ongoing program. However, there are many other attributes besides the software process that are important in determining the most qualified contractor to do a job.



Figure 1-7 Sample of Contractor Attributes That Could Be Considered in a Software-Intensive Acquisition

Figure 1-7 depicts the software intensive attributes of a contractor's organizational site and those considered by SCE. an SCE site visit to a contractor's facility is an intense examination of the organization that reveals its software development process capability and improvement activities. All of the attributes shown above are important to an

acquisition, but only those related to software process are captured and recorded in the findings during the SCE site visit.

Areas other than software process—tools, systems engineering, and skill and experience with a particular language—should be investigated also. These items should be investigated outside the structure of the SCE site visit to ensure repeatability, consistency, and reliability of the method. This is important to ensure fairness and equitable treatment of all competing offerors during a source selection. While the SEI supports the need to review other critical areas that are not covered in the CMM KPAs, no attempt to merge these areas into the SCE findings should be made on site. The current method of teaching and conducting an SCE site visit follows the decomposition of the CMM along the lines of the KPAs.

The Results of an SCE

Findings of strengths, weaknesses, and improvement activities against the CMM KPAs are the result of an SCE. The SCE Method is essentially a data collection activity which extends insight into an area which has been lacking in the past: software process capability. Figure 1-8 shows a sample of a detailed finding for the Software Project Planning KPA.

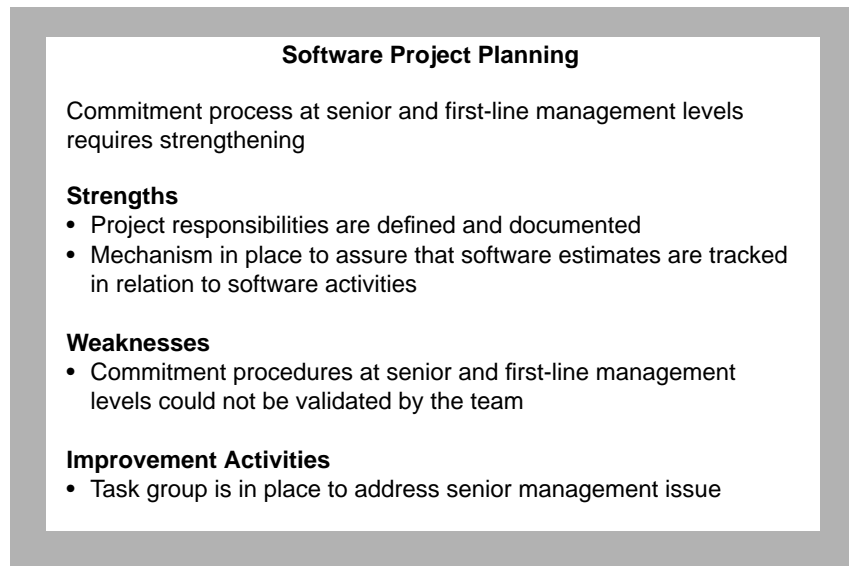

Figure 1-8 Sample Key Process Area Finding

Comparing SPA and SCE

The SEI has developed Software Process Assessments (SPA) and SCE as part of a strategy to improve the state of the practice in software engineering. Both methods address the SEI vision of supporting the evolution of software engineering from an ad hoc, labor-intensive activity to a managed, technology-supported engineering discipline. Differences in the methods stem from the motivations, objectives, outcomes, and ownership of findings. These factors lead to substantive differences in interview dynamics, scope of inquiry, information being gathered, and formulation of the outcome (findings).

Figure 1-9 highlights several of the major differences between the two methods which affect the way they are performed.

Assessment	Evaluation
Used by organization to improve its software processes	Used by acquisition organization in source selection and contract monitoring
Assesses process practice	Substantiates current practice process
Acts as catalyst for process improvement	Evaluates contractor's commitment to improve
Provides input for improvement action plan	Analyzes contract performance potential
Findings may include issues not explicit in the Capability Maturity Model	Findings restricted to Capability Maturity Model issues
Collaborative: members of organization must be on team	Third party oriented: members of organization not on team
Applies to organization, not individual projects, contracts	Organizational data but applied to a specific contract award on acquisition
Input for improvement action plan to unfreeze organization	Input for award decision, contract monitoring, or risk management

Figure 1-9 Differences Between Process Assessments and Capability Evaluations

Critical differences an SCE user must understand are the basic assumptions built into the methods themselves. First, the current SPA method assumes that members of the organization will cooperate openly, fully, and in a manner that provides factual contributions. This assumption is made because presumably participants have no reason to mislead SPA team members, who are from their own organization, and are dedicated to improving the organization with the full support and commitment from senior management. The SPA findings are intended to be incorporated into action plans for organizational improvement, and therefore do not verify findings, by examination of documentation, every assertion made during the interview process. SCE assumes that members of the evaluated organization will make every

attempt to put their organization's software process capability in the best possible light. This is because their company's livelihood and therefore their own careers and livelihoods may be at stake since the SCE findings are used as factors in determining potential monetary awards to the company. Thus, every attempt is made by the SCE team to verify facts through use of a document review process.

an SCE team consists of one acquisition team leader and three to five acquisition personnel and/or their engineering support contractor personnel. This team may include a procurement member or observer. The SPA team consists of six to eight members either entirely from the organization itself, or from both the organization and either the SEI or one of the SEI's licensed SPA vendors.

Finally, SPAs are longer in duration, involve more people from the assessed organization, and are generally more costly than evaluations. SPA data is not recommended for use on government source selections because of the inherent differences between the two methods as explained above. Little information from SPAs can be directly applied by an acquiring organization for the purpose of selecting the most appropriate offeror.

The methods are similar in that they both use the framework of the CMM to structure a detailed investigation into software practices, and both require extensive training and experience to conduct properly. SPA training does not prepare a team to perform SCEs, and SCE training does not prepare a team to conduct SPAs.

Both the SPA and SCE methods seek to identify the organization's software process strengths and weaknesses as measured against the KPA goals of the CMM. Both seek to motivate the contractor to address the major weaknesses in an aggressive software process improvement plan. However, the source of the improvement motivation is clearly different.

The findings from an SCE deal strictly with organizational strengths and weaknesses against the CMM, not recommendations to rectify the problems as is the case with SPA.

The differences between the two methods are important to acquisition managers. It is important because the acquisition organization may benefit in the long run by conducting business with contractors that are implementing software process improvements. Although SCE use may focus the attention of senior executives on investments in software process improvement, the greatest benefits will be apparent to those firms who have embraced the concepts of process improvement without acquisition organization pressures or incentives. Acquisition managers must understand the limitations posed by SCE and SPA, and how they relate to their acquisition.

Facilitating SCE on Your Program

Integrating the SCE Method into an acquisition involves four steps:

1. Identifying the maturity of the contractor's current software process in terms of strengths, weaknesses, and any improvement activities relative to the CMM KPAs.
2. Assessing program risk and how the contractor's improvement plans alleviate that risk.
3. Making continuous process improvement a part of the contractual relationship with the contractor.
4. Monitoring software process performance and developing a working relationship with the contractor (as opposed to an adversarial relationship).

The SEI provides briefings and presentations to acquaint sponsoring organizations with the evaluation method. If a sponsoring organization decides to use the evaluation method, it sends representatives to the SEI training courses: SCE Overview Seminar and SCE Team Training. The overview helps the sponsoring organization realize the

implications and benefits of using software capability evaluations, and the team training helps teams prepare to conduct an SCE. They can then conduct a pilot use of SCE. After completing several pilots, the sponsoring organization decides whether to install the evaluation method on a broader scale. A typical timeline for transferring the evaluation method into routine practice is outlined in Figure 1-10.

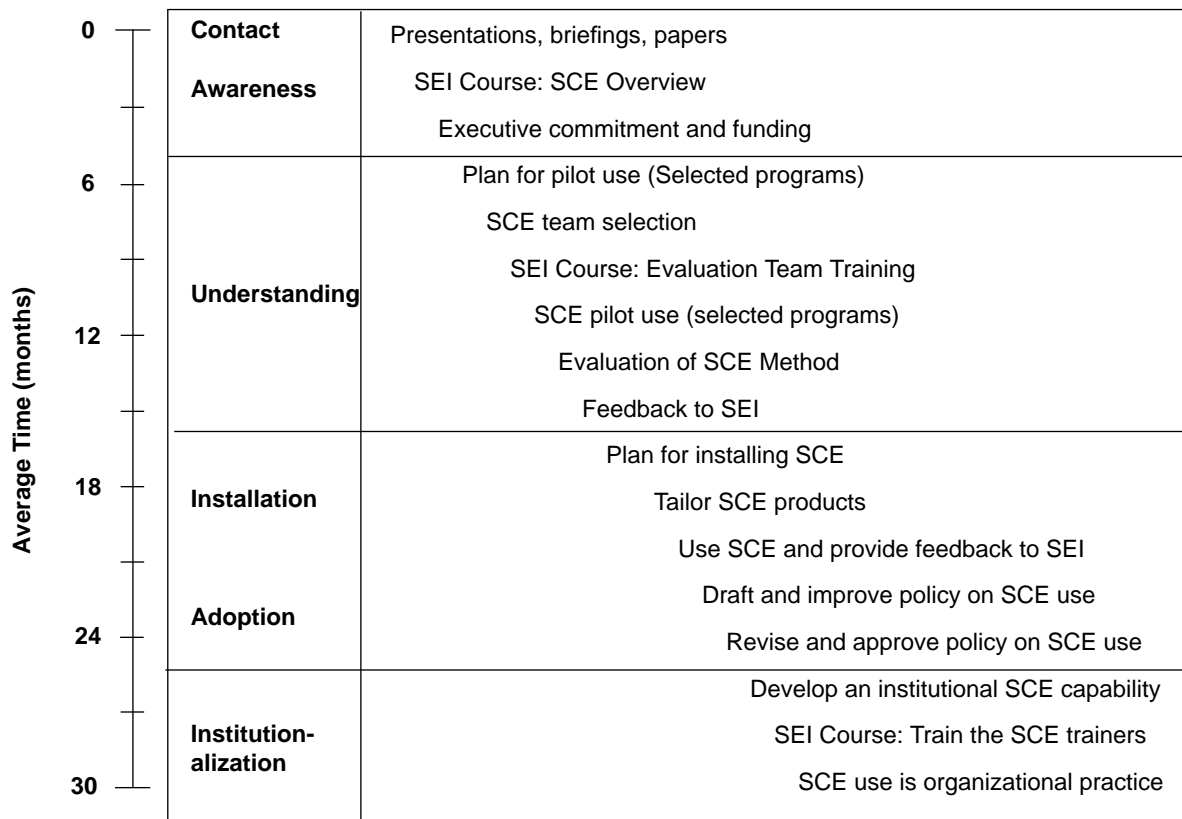

Figure 1-10 Steps for Transferring the Evaluation Method into an Organization

Once the CMM is understood, the different applications of the CMM are recognized, a sponsoring organization can begin, at a macro level, completing the activities of the checklist found in Figure 1-11.

Planning The Implementation of Software Capability Evaluation
<ul style="list-style-type: none"> <input type="checkbox"/> Attend SEI Course: SCE Overview <input type="checkbox"/> Selected engineering staff should read remainder of guide <input type="checkbox"/> Determine program use <input type="checkbox"/> Include SCE Method in appropriate documents <input type="checkbox"/> Select, register, and train SCE team <input type="checkbox"/> Conduct SCE, save results, and capture lessons learned <input type="checkbox"/> Brief the SEI on use of SCE

Figure 1-11 SCE Implementation Checklist

The SCE Method is flexible because the application of the method can be tailored without changing the conduct of the site visit. Thus, different types of acquisitions, types of processes, size of an organization, and degrees of process automation or use of tools can be accommodated by the method. It is acceptable to have alternative approaches to implementing SCE within a specific context. The intent, however, is to have the site visit itself be identical, a “black box,” from site to site. In other words, Army Material Command (AMC) may do source selections differently from Air Force Electronic Systems Center (ESC) and the Naval Command, Control and Ocean Surveillance Center (NCCOSC), RDT&E Division (NRAD), but all should perform the SCE Method the same way. This ensures flexibility in the use of the method while ensuring reliability, consistency, and repeatability of the evaluation method itself.

Below are important roles when SCE is being applied in a government acquisition:

The **Source Selection Authority (SSA)**, who is responsible for the efficient and proper conduct of the source selection process.

The **Source Selection Advisory Council (SSAC)**, which ranks offeror proposals according to an evaluation plan.

The **Source Selection Evaluation Board (SSEB)**, which evaluates offeror proposals.

The **Source Selection Evaluation Team (SSET)** is a combined SSEB and SSAC. They perform the responsibilities set forth in AFR 70-15 and AFR 70-30. ESC uses either an SSEB or SSET on their source selections, from here on the use of SSEB/T or SSET will refer to either SSEB or SSET, whichever structure is being used.

The **Procuring Contracting Officer (PCO)**, who is responsible for solicitations and contracts, communications with offerors, consistency of the source selection plan with the Federal Acquisition Regulation (FAR), contract award, and other requirements and functions specified in the FAR except the source selection responsibilities of the SSA.

The **Program Manager (PM)**, who is responsible for developing and implementing the acquisition strategy, preparing the source selection plan, and obtaining SSA approval of the plan before issuance of the Request For Proposal.

The **Software Capability Evaluation team** is sponsored by the acquisition organization and consists of a group of four to six appropriately experienced (e.g. education, domain expertise, numbers of years experience) personnel who are trained in applying the SCE Method. The SCE team is responsible for applying the SCE Method, including preparing for and conducting the site visits and reporting the findings.

Care in implementing SCE is important. The SCE team must be properly selected and trained to prepare the team for the site visit. Only experienced and trained teams can use the SCE Method in the intended manner. Training consists of two courses. The first, Software Capability Evaluation Overview Seminar, provides a briefing on the concepts, benefits, and guidelines and logistics of SCE to the acquisition management team. The second, SCE Team Training, provides a review of

software process capability relative to the CMM, how to conduct an SCE site visit, and team development activities including case studies for SCE team members.

Chapter 2 Preparing to Use SCE

Some of the steps required to prepare for an SCE are specific to its use. Preparation for performing an SCE site visit includes the following:

- Determining SCE use.
- Selecting the SCE team.
- Training the SCE team.
- Providing directions to the contractor.
- Screening contractor responses.
- Preparing on-site materials.
- Coordinating on-site activities.

The timeline in Figure 2-1 shows when each activity should occur. It is generic, and is not reflective of actual effort required for each task. Each program office should tailor this schedule of activities to meet the needs and constraints of its specific acquisition.

Determining SCE Use

Note in Figure 2-1 the significant amount of time allowed for determining how to use SCE. Organizations should use this time to consider the varying methods of implementation and the individual techniques and procedures that may be used. The range of time for each activity will vary with the experience of the team. Those organizations familiar with SCE use will spend significantly less time on the intervening steps once the decision to use SCE has been made.

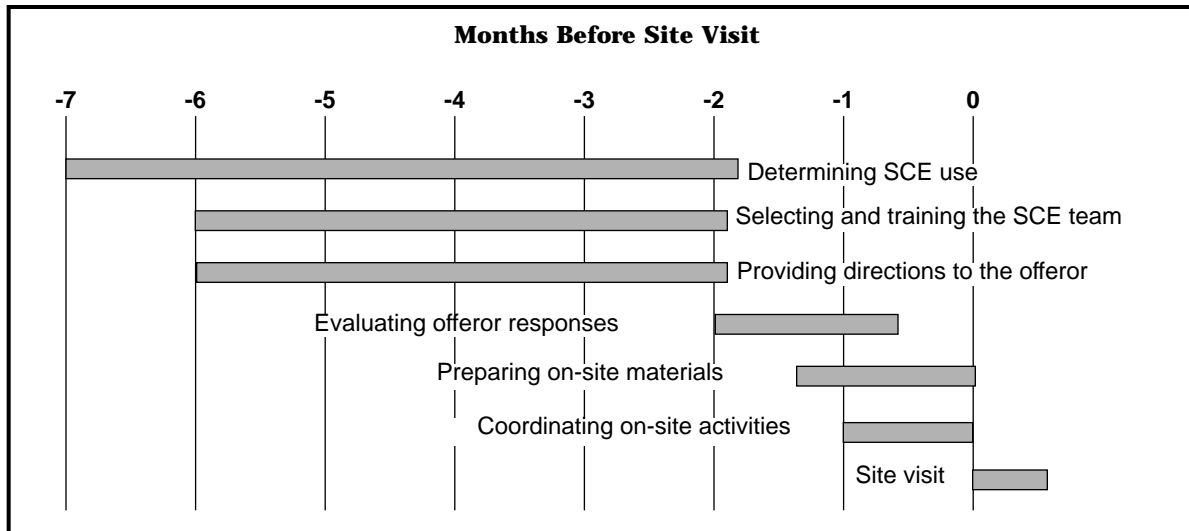

Figure 2-1 SCE Preparation Timetable

The acquisition organization must decide how to factor the SCE findings into the acquisition. Part B of this document explores these issues and others a program office must consider to use SCE in a source selection. Experience has demonstrated the need for preparing as early as possible, particularly in large, understaffed acquisition offices. Additional preparation time may need to be factored into the schedule in anticipation of gaining approval to proceed with the SCE. For example, contracts for small or small, disadvantaged businesses require extra preparation and approvals outside the normal chain of command.

Selecting the SCE Team

Selecting qualified, experienced software acquisition personnel to serve as SCE team members is one of the most difficult and important tasks a program or software manager may do in the course of implementing SCE in an acquisition. The key considerations for assembling a SCE team are

- Individual experience.
- Team skills and experience.
- Individual interpersonal skills.

Individual Experience	<ul style="list-style-type: none"> • Team leadership skills, team building activities, and team staffing. <p>SCE team members should be selected from the most experienced people in the program office, qualified personnel from field organizations (laboratories), qualified engineering support contractors (e.g., MITRE, Aerospace, IDA), and people from other program offices that can be used on a temporary basis. The most successful teams will be those that average at least seven years of software and/or software acquisition experience across the team. At least one member of the team should have source selection experience. This is important because what can and cannot be done during a source selection is different from what is permissible after award. An acceptable spread of experience levels that have been found to be successful in an SCE team is</p> <ul style="list-style-type: none"> • At least one or two senior personnel (more than seven years appropriate experience). • Two or three mid-level personnel (five to seven years appropriate experience). • One junior person (two to four years appropriate experience) Note: This is a recommended maximum. Junior personnel typically will not have the background to understand certain aspects of software processes they will observe.
Team Skills and Experience	<p>The background of SCE team members should strike a balance between software technical, software management, and software acquisition experience. They should, as a minimum, share a mix of knowledge and experience in the following software engineering disciplines:</p> <ul style="list-style-type: none"> • Acquisition policies and procedures (particularly source selection procedures). • Project management and planning. • Software configuration management.

- Software design, development and methodologies.
- Software quality assurance.
- Systems engineering.
- Technical requirements of the contract.
- Testing.
- Application domain, e.g. Avionics, Missiles, C3I, databases.

In general, expertise will be necessary from at least one team member in each of the key process areas to be investigated. Certain areas may be stressed over others depending on the acquisition.

Interpersonal Skills

SCE team members must be “team players.” Conducting SCEs requires professional judgement and team consensus—attributes that are necessary to work effectively in an SCE team are patience and perseverance. Past experience has demonstrated that if team members lack interpersonal skills—essential to fostering good, open communications between team members and the contractors—the team is less effective, less credible, and less motivated to fulfill the SCE objectives. The ability to communicate with the contractor and other team members is the essence of SCE teamwork.

Team Leadership Skills

Experience shows that an effective team leader is critical to the operation of the team. The team leader

- Ensures that the team meets its schedule and objectives, encourages teamwork and consensus building.
- Is the SCE team focal point for both the acquisition office and the contractors (planning, scheduling, communicating).
- Should have enough basic leadership skills to ensure that the team functions effectively.

Team Building
Activities

The team leader should be the one most qualified, based on knowledge, experience, and amount of direct SCE site visit experience. Occasionally, teams can break down when an inappropriate team leader is appointed. Program office management should prevent this from happening. Previous SCE experience should be a criterion for assignment as an SCE team leader. New SCE team leaders should have participated on at least two SCEs as a team member before assuming a leadership role. This experience of participating on SCEs will prepare the new leader to understand the SCE team process, team dynamics, and contractor sensitivities.

An essential aspect of preparing a team to conduct an SCE is performing team building activities before going on site. Assume the SCE team has never worked together. An activity that would help bring the individual members together as a team could be an exercise whereby a simple task is assigned and discussed. For example, each team member would interview the person to his or her right at a table or in a room. The task of the interviewer is to learn the person's background, interests, and area of expertise. Each team member would then introduce and briefly state the results of their interview. The team could then identify its relative background expertise areas to the evaluation task they are being asked to perform. For reference, the bibliography in Appendix C of this guide contains three references, [Bucholz 87], [Denton 89], [Kelly 91], that contain more on teams and team building activities. These exercises will help determine how the team members work together. Often, many months may pass after teams have completed SCE team training and before they conduct site visits. The team building activities are important for the team members to re-acquaint themselves as a single operating entity able to reach consensus effectively. There may be times when trained individuals are brought together who have not completed training together. In this scenario, team building is crucial, since they have not operated as a team before.

The success of the SCE team hinges on its ability to identify and reach consensus on the strengths and weaknesses of a contractor. An SCE team is neither an autocracy, where the leader dictates what decisions are made, nor a democracy, where the team votes and the majority prevails. Instead the decisions are reached by team consensus, meaning all members agree to the findings, and there is no significant minority dissent on issues. If consensus on an issue cannot be reached, then there is no finding in that area. This is where team building activities will pay large dividends.

Team Staffing

Staffing the team is another issue for consideration. Creating a “software center of excellence” is an excellent mechanism for building a core of individuals who are highly skilled in conducting SCE.

System Program Offices will normally draw SCE-trained personnel from within their own organization. If this pool does not have enough individuals, a request to the “center of excellence” organization would then be made to assist in identifying team members. In this manner, the program office can take advantage of key components mentioned above under individual and team skills. This alternative makes better use of limited software skilled resources while ensuring that the program office acquisition expertise, knowledge of the product type and contractor base, and “domain” knowledge of the product to be acquired is present on the team. Furthermore, the core resources will become valuable assets to the organization as they gain more experience conducting evaluations for multiple acquisitions in different programs.

Training the SCE Team

Training, preparation, and experience separates good SCE teams from poor ones. There are three levels of training needed before an individual should be considered fully qualified to conduct SCEs:

- Preparation
- Coursework
- Experience

Preparation

The preparatory stage consists of on-the-job experience, prior training, and professional reading. It is recommended that SCE team members take courses in team work, assertiveness training, and total quality management. Watts Humphrey's book, *Managing the Software Process* [Humphrey 89] and the latest release of the CMM [Paulk 93a] are two essential readings that are provided to participants of the evaluation team training course. Participation in the one-day SCE Overview Seminar is also beneficial background to prepare team members.

Coursework

SCE team training consists of a multi-day, case-study-oriented course that all SCE team members must successfully complete. This course is intended for experienced personnel who have been selected to conduct the SCE Method. It provides the knowledge and reinforces the skills required to conduct SCEs effectively, and helps the group develop into a cohesive team. A sampling of course content follows:

- Team building exercises.
- Preparing for the site visit.
- Conducting interviews.
- Substantiating key practices.
- Reviewing documents.
- Developing and presenting findings.

SCE teams need effective communicators willing to take on different roles (e.g. facilitator, recorder, interviewer, timekeeper), as demanded by the dynamics of the team and constraints of the acquisition. The SCE team needs to know how to evaluate the contractor in relation to the CMM, so a working understanding of the CMM is required. Teams are taught that processes implemented are to a large degree dependent on several non-process variables. It takes experience to understand these relationships and exercise professional judgement, which is why the team characteristics

and profile are crucial in addition to the coursework. Roles taken on by team members to accomplish the site visit include the following:

- Team Leader: manages process, keeps to agenda, guarantees deadlines and deliverables.
- Facilitator: sustains team spirit, moves team toward consensus, and encourages participation.
- Recorder: captures information, does not editorialize, and lists documents to be reviewed.
- Participant: assists other team members and carries out assigned tasks.

Experience

Every graduate of the SCE training program should be a member rather than a leader of an SCE team for at least two SCEs. Junior- and mid-level personnel should take part in at least three SCEs before being considered for the team leadership role. Resource demands and time constraints, however, may prevent this from happening. When working under such constraints, it is recommended that the program office send the team to practice an SCE on a volunteered organizational office before beginning the source selection. One acquisition team practiced doing SCEs on at least three occasions to insure personnel were highly trained for the source selection.

The common denominators in discussions with individuals returning from their first SCE is their desire for more team training, preparation, and time to conduct the interviews. SCE's activities are not radically different from those done in the program office on a day to day basis. Taken together, however, they are group activities requiring significant practice and preparation. Practicing as a group will reveal individuals' strengths and weaknesses, depth of required preparation, and how to manage the SCE process to capitalize on the team's strengths so that more effective and timely SCEs are conducted.

Providing Directions to the Potential Offerors

Acquisition Documents

SCE in source selection provides the program office with several opportunities to interact with the potential offeror(s). The program office will need to provide directions in the Instructions For Proposal Preparation (IFPP) explaining how to complete the preparatory materials that form the initial baseline of the site visit. They will also have to present the SCE process and describe how the findings are factored into the acquisition at either a Pre-proposal Conference or, in the acquisition documents or both. Part B of this document will discuss in detail the areas requiring acquisition organizational direction and interaction with the contractor.

For this discussion the use of SCE will affect the following acquisition-related documents. Documents with an asterisk (*) after them provide direction and information to the contractor community in an acquisition, while the others are acquisition organization internal documents.

- Commerce Business Daily Announcement*
- Source Selection Plan (SSP)
- Source Selection Evaluation Guide (SSEG)
- Pre-Proposal Conference *
- Request for Proposal (RFP)* - Sections H, M, L, (IFPP)
- Possibly—Statement of Work (SOW) or Award Fee Plan*
- Debriefings of Unsuccessful Offerors*

Contractor Project Profiles and Maturity Questionnaire Responses

The acquisition organization will request the offerors to prepare and submit profiles and Maturity Questionnaire responses for each of six to eight projects that are representative of the software development work at the site(s) that is being proposed. This is discussed further in Part B of this guide. For the remainder of this chapter discussion, only the highlights of preparation, conducting the site visit and the final reports will be covered.

Requests for Other Information

The contractor's organization charts specific to the organizational site and the projects to be submitted for consideration by an SCE team are particularly helpful in building a preliminary plan of who is to be interviewed to discuss certain issues. Request after competitive range determination and before site visits only that documentation which the SCE team has time scheduled to review and has factored into its planning activities. Providing documentation is a burdensome task for the contractors and reviewing it is a time-consuming activity for the SCE team. Select only what is essential based on analysis of contractors' responses and only if time is available. Documents that will reveal processes at work should be selected over those that are technical in nature or discuss plans. (Plans often are not implemented or updated and are good only as a point of departure.)

Preparing and Conducting the Site Visit

The following discussion is a brief overview of the essential steps required to execute the SCE on-site period. It is included here for continuity of the Part A Discussion. Detailed discussion are available in a separate SEI Document, the *Software Capability Evaluation Version 2.0 Method Description* [SCE 93].

Preparing for the Site Visit

- Developing the acquisition product profile and Target Process Capability. The Target Process Capability is the explicit identification of the software process scope to be evaluated. SCE uses the KPAs of the CMM to "target" the areas of software process capability investigation.
- Selecting contractor projects.
- Identifying Critical Subprocesses for all contractors.
- Analyzing the contractor's project profiles and Maturity Questionnaire responses with respect to the product profile and the TPC. Note: The Maturity Questionnaire is used only as an input, in conjunction with the analysis of

Project Profiles, with respect to the *Product Profile* and the Target Process Capability. The Maturity Questionnaire is not scored by the SCE team.

Conducting Site
Visits (For Each
Contractor)

- Determining key issues for individual contractors.
- Developing initial exploratory interview questions.
- Developing an agenda and schedule for initial exploratory interviews and document reviews
- Notifying individual contractor focal points of SCE team logistic requirements.
- Presenting the arrival brief to contractor management.
- Analyzing organizational and project documentation.
- Reviewing agenda and schedule.
- Conducting exploratory interviews.
- Requesting additional documentation.
- Validating interview responses.
- Drafting preliminary findings.
- Validating preliminary findings.
- Conducting consolidation interviews.
- Validating improvement activities.
- Collecting final data.
- Developing final findings.
- Concluding meeting (as prescribed by Procuring Contracting Officer (PCO)).

Development of
Findings

Using its collective professional judgement and a consensus decision making process, the SCE team puts together its findings from individual projects to create a set of overall findings. These findings are the embodiment of all the

interview and documentation notes developed before and during the on-site review. Detailed findings should be prepared for each KPA investigated.

Findings should be specific to the point where they identify the cause for a strength or weakness, but not so specific that the finding places the team in a corner by failing to consider exceptions that may exist within the organization. SCE teams must remember they are evaluating a subset of the total projects ongoing at a site as a proxy for predicting the organization's capability to do a specific project, and exceptions may exist because of this process. The team should be prepared to substantiate the strengths and weaknesses without attributing the information to specific individuals or projects. Individual confidentiality is a vital component of a good site visit. The team should create and maintain a detailed record of the site visit which the contracting officer can include as part of the documentation making up the permanent contract file.

Part B Using SCE in a Source Selection

Introduction

The next three chapters explore in depth the role of SCE throughout the source selection process. First a high level look is provided, then some key issues which should be considered when using SCE are explored. Part B will give the reader a realistic understanding of the extensive planning required to implement SCE in a source selection. SCE is more than a series of site visits followed by an outbrief to the Source Selection Advisory Council (SSAC), Source Selection Evaluation Board (SSEB) or equivalent organization under streamlined source selection procedures.

Figure B-1 provides a high-level flow chart of the normal source selection activities that will be affected by the incorporation of SCE into the source selection process. The chart simplifies somewhat the multitude of interactions that go on during the planning and execution of SCE. The first step in the process is to decide whether SCE should be used in the source selection process.

Chapter 3 places SCE in the context of a typical source selection by discussing issues that should be considered. These issues include criteria, costs and benefits of using SCE, both for the acquisition organization and for the offerors. Chapter 3 also looks at the personnel involved in the SCE process.

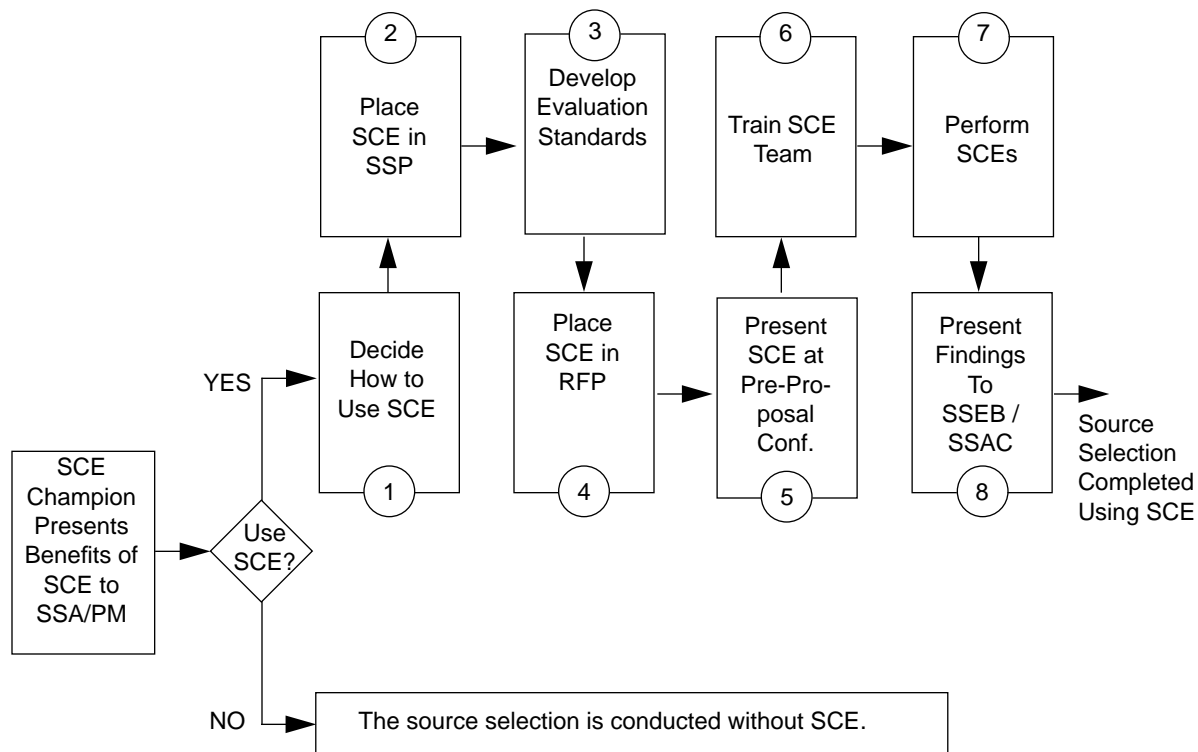

Figure B-1 Source Selection Activities Affected By SCE

Once the organization has decided to use SCE in an acquisition, the proper role for SCE in the source selection criteria must be assessed. This decision point is labeled with a “1” in Figure B-1. Should SCE be factored in as a Performance Risk Assessment or Evaluation Criterion or both? Chapter 4 discusses some alternate methods of using SCE findings in the source selection decision. It also addresses the implications of using SCE on the source selection schedule.

The boxes labeled 2 through 5 address documentation typically required for a source selection, whether SCE is used or not: Source Selection Plan (SSP), Pre-proposal Conference presentation, Evaluation Standard, and the Request For Proposal (RFP). Each piece of documentation must address SCE to a certain degree. Chapter 5 explains how to develop these documents to accommodate SCE.

Like all schedules, timetables, or flow charts found in this guide, Figure B-1 is only a representation giving the user of SCE insight into what is required to implement SCE effectively. Variations to the schedules and timetables should be expected. For example, SCE training could easily be carried out before the Pre-proposal Conference and/or the writing of the Evaluation Standard in order to accommodate the unique demands of the acquisition.

Chapter 3 Deciding to Use SCE

Criteria for Using SCE in a Source Selection

This section introduces the issues that must be considered when contemplating use of SCE in source selection. General familiarity with the acquisition organization source selection process is assumed for purposes of focusing on each player's relationship to SCE. Appendix A: SCE Participants in Source Selection provides a brief discussion of each primary Source Selection participant that is affected or can affect the use of SCE.

Clearly, SCE should not be used for every software acquisition. Both the costs and benefits of using SCE as well as the specific nature of the acquisition should be considered when making this decision. These costs and benefits may indicate that other approaches are necessary for very small acquisitions involving software. This section discusses criteria related to the nature of an acquisition.

There is no minimum number of lines of code or measure of software intensity dictating that SCE must be used in an acquisition. Several considerations must be weighed by the program manager when making the decision. Each of the following factors are important considerations, but the program manager or person responsible for determining SCE usage for an acquisition must weigh these factors in accordance with their organization's method of procuring systems. These are general guidelines that must be refined to meet the context of the organization:

- Criticality of an acquisition or the software component.
- Total dollar value of the acquisition or software component.
- Management control priority.
- Unprecedented system mission needs.

- Acquisition life cycle phase.
- Length of acquisition time period.
- Software size, the number of Computer Software Components (CSCs), and the prime contractor - subcontractor relationship.

Figure 3-1 illustrates the relationship of each of these factors as a general guideline for determining appropriateness of SCE usage. Each box should be read independently, and then combined with other factors, to make an overall judgement on SCE applicability.

Criteria Decision	Critical Software	Dollar Value	Management Control	Software Precedence	Lifecycle Phase	Schedule Length	Software Size
Definitely use SCE	Major government program MCCR systems	Software > \$5M	High Priority	Unprecedented system	EMD phase	Upgrades, major modifications, or follow-ons expected	> 100 KSLOC
Strongly Consider Using SCE		Total program > \$25M		Need defined, any software CSCs unprecedented	Dem/Val Concept exploration	Development > 24 months System life > 10 years	> 50 KSLOC
Consider Using SCE	Non-MCCR systems	Total program > \$10M		Precedented system	Operational readiness support	Program length ≥ 5 years	> 25 KSLOC
SCE Use Likely not Appropriate		Software < \$5M, < 30% of total cost Total EMD < \$10M	Low priority		Production /deployment		< 25 KSLOC

Figure 3-1 SCE Usage Decision Making Criteria

Criticality of an Acquisition or the Software Component

The criticality of an acquisition may necessitate SCE use. The SEI recommends that any government-defined major program use SCE as an integral part of its strategy for producing the highest quality end product and motivating government contractors to focus on software process improvement as a means to effect this goal. In all Mission Critical Computer Resource (MCCR) systems, regardless of total dollar amount, software size, or DoD priority ranking, SCE use should be strongly considered. MCCR, and software in general, are critical components of modern weapon systems. The success of the system is largely dependent upon software precisely performing its intended function. An example of a small, but highly critical piece of software warranting the use of SCE in an acquisition would be software needed to control the hardware for an access control system for nuclear weapons or other munitions.

Total Dollar Value of the Acquisition or Software Component

Dollar value is important because of the investment in resources and time necessary to implement SCE effectively. Use of SCE should be considered when the total value of an acquisition software component exceeds \$10 million. On any acquisition in which total cost is greater than \$25 million, SCE use should be strongly considered.

Where the software component of a program itself exceeds \$5 million or is greater than 30% of the total program cost, SCE should be used. This criterion may often take precedence over the \$25 million threshold described above. On the other hand, some acquisitions in the \$10 to \$25 million range may not warrant the use of SCE because of program-unique circumstances. Perhaps the software component is not mission critical and is less than 10% of the total dollar value. These guidelines are not absolute; they are intended as guidelines to aid the decision-making process and the development of appropriate policies and procedures.

Management Control Priority

When management control is a high-priority concern, SCE use should be considered. An environment under effective management control will be more able to produce data that is useful for lessons learned which can be incorporated into the

overall systems development process. These lessons help the acquisition organization avoid “re-inventing the wheel.” Successful management control also facilitates effective implementation of modern methodologies, tools, and techniques.

A controlled environment is essential to managing contractor processes—processes for maintaining the development environment, bringing new people and technology into the environment, identifying problems early in the contract, and managing requirements changes. A controlled environment enables improved risk assessment and abatement.

System/Software
Precedence

SCE should be used when the contractor is likely to develop software implementations that are unprecedented. When the mission of the system/software component, especially the role played by the software component, is known and defined by the end user, and portions of the system will be unprecedented, use of SCE should be strongly considered. SCE helps identify program risks associated with the capability of contractors to succeed in producing quality software in an unprecedented environment.

Use of SCE yields information about an organization’s ability to manage risks inherent in unprecedented software development, as well as their ability to manage tasks which are new, but are similar to ones they have successfully completed previously.

Unprecedented systems (i.e., those solving new or unique problems) pose special problems for software development organizations. An SCE of each offeror would identify whether the requisite controls are in place on the contractors’ existing programs and whether they will be easily transferred to the new, unprecedented system.

Acquisition Lifecycle
Phase

The lifecycle phase of an acquisition is an important factor in determining SCE usage. The SCE Method and CMM were originally developed in response to DoD’s and industry’s recognized problems in managing the development of increasingly complex mission critical, software-intensive products in the real-time, embedded domain. Given this

background, SCE fits in any engineering manufacturing development (EMD) program within this domain, since EMD is the typical phase associated with major new software development. The SEI recommends that any EMD program consider SCE use, in accordance with the other factors listed here. However, SCE use is not limited to the EMD phase. The SCE Method has been used successfully in demonstration/validation, concept exploration, and operational readiness support phases.

Length of
Acquisition Time
Period

The SCE Method should be considered in any procurement where software is a major component and the program duration period is expected to be greater than 24 months. This timeframe is recommended because of the amount of resources necessary to apply SCE effectively, and because the typical process improvement program implemented by a contractor requires at least 18-24 months to attain and sustain improvements in process maturity. Thus, more software development time is necessary to see improved results directly on the contract.

SCE should also be used when the program office expects significant block upgrades, modifications, or follow-on programs to occur, and the original contractor is expected to be a primary offeror or likely performer of the new work. Often, the processes put in place by the contractor at the start of a software development will be frozen, meaning that process changes will be limited during that development period. Software upgrades or major modifications to existing systems are good times to unfreeze the current software development process and install new, improved processes, methods, and technology. Therefore, using SCE during the initial software development and the subsequent improvement programs will enable any improved processes to be implemented on the follow-on developments.

SCE use may still be appropriate even if neither of these criteria are met if government Program Executive Officer (PEO) center/commander or activity committee is attempting to motivate and gain improvements in a particular domain

Software Size,
Number of
Computer Software
Components, and
the Prime
Contractor-
Subcontractor
Relationship

area, such as avionics systems. These PEO decisions may entail long-range considerations which go beyond the current contract award, and thus SCE use may be appropriate to meet other government objectives.

The amount of software to be developed will directly affect relationship to the number of CSCs required to effectively partition the software system into manageable chunks and the likelihood of a prime contractor performing integration of software produced by several subcontractors. When the estimated size of the software component exceeds 100 thousand source lines of code (KSLOC), SCE should be used. At this threshold, the complexity of the software development will likely cause the ability to manage a large number of CSCs and subcontractors to be a significant concern of the program manager. Scaling up small software engineering teams to meet the challenges of a large development creates additional pressures on effective software development processes.

There are several related considerations that should also be weighed by the program manager when determining whether to use SCE:

- Software size between 25 and 200 KSLOC.
- Minimum development team of 20 to 100 people in under a year with several years of support and enhancements.
- Software embedded on multiple platforms in different languages for a real-time application.
- Highly specialized technologies: for example, radar signal processing on a unique programmable signal processor or image processing on a customized parallel processor.
- Software pieces to be subcontracted to geographically distant locations.

These examples highlight different managerial/technical capabilities a contractor must possess depending on the type, complexity, and size of the software and the nature of the delivery schedule.

A clear understanding of acquisition-specific circumstances, rather than knowledge of hard criteria, is necessary to determine whether SCE use is appropriate. In general, for all acquisitions with a software component, the acquisition organization should seek to do business with contractors who understand and effectively implement modern software development practices, and also with those contractors taking actions to improve these practices. SCE is a tool that can augment other acquisition organization techniques for discerning differences in the capabilities of offerors.

The SEI has been piloting the SCE Method with organizations in the Army, Air Force, and Navy since its inception in 1987. Several organizations have begun to establish criteria for SCE use which reflect the individual needs of these organizations, and supplement the information contained in this section of the guide. One major command has drafted a policy requiring SCE use on all MCCR programs exceeding \$10 million.

Another military division is taking the approach of requiring SCE use on procurements which include software size estimates greater than 50 KSLOC. These examples underscore the importance of refining SCE usage criteria to best reflect the acquisition practices implemented at a particular acquisition organizational site. Different organizations have different business bases, contractor communities, product types, application domains, etc., all of which affect site-specific implementing instructions for SCE.

Pilot use of the SCE Method in Army, Navy, and Air Force indicates that SCE helps the acquiring organization in many ways:

- Added software development capability realism in the source selection process.
- Increased objectivity in information collected for an acquisition.
- Motivation for contractor software process improvement actions.

Benefits of Using SCE in a Source Selection

Software Development Capability Realism: One benefit SCE provides is the software development capability realism introduced into the proposal review and contractor analysis process. The information SCE collects is timely, real and based on current projects and the practices actually being implemented by offerors' engineering and managerial personnel.

For moderate to large software development efforts, a currently popular means of evaluating a contractor's software development abilities during a source selection is the review of the offeror's Software Development Plan (SDP).

Comparing the SCE findings with the evaluation of the contractor's proposal and SDP will clarify for the program office whether the proposed approach is realistic in light of the offeror's current process capability. Based on this comparison, the program office can better evaluate the risks posed by each offeror and work with the winning contractor on a realistic software process improvement program.

Objectivity: A second major benefit of SCE is the objectivity it introduces in the proposal review process. The SCE Method helps ensure an objective review by putting a trained evaluation team on site to evaluate the offerors activities and compare them against a public standard, the CMM. In the typical source selection, evaluating software risk is a difficult task because there are few avenues for addressing this issue other than by evaluating what is in the proposal.

With the goals of the CMM KPAs as a basis, contractor software process capability can be reliably measured against a common standard. This permits consistent, repeatable, and fair evaluation of contractor software process capability. This adds value to the source selection process by making software reviews more objective.

Motivation for contractor software process improvement actions: In order to remain competitive on successive acquisitions, contractors must improve their software development processes. In contract monitoring, capability evaluation can be used to measure progress relative to that

measured during source selection, augmenting an action plan for improvement. The Performance Risk Analysis Group (PRAG) can evaluate process improvement based on past performance risk assessments of the software process.

By making SCE a discriminator in conducting acquisitions, program offices will motivate contractors to focus on software process capability as a means of retaining or increasing acquisition agency specific business. Given the premise that product quality will follow process quality, focusing on software process improvements resulting in increased process maturity will increase the likelihood of

- Accurate estimates.
- Decreased variance among projects.
- Reduced cost and schedule targets.

Although there is no definitive study validating these benefits quantitatively, there is significant anecdotal evidence from individual government and industry organizations to suggest these benefits are real.

A focus on improving software process capability should lead to error prevention, earlier detection of errors in the lifecycle, and an ability to manage requirements changes effectively. Improvement in processes which yield earlier detection of errors and better management of the requirements change process should save the acquisition agency money over the lifecycle of major systems.

Cost of Using SCE

Using SCE requires personnel and financial resources, on both the contractor and acquisition agency sides. The resource considerations affecting the implementation of SCE are

- Personnel
- Time
- Financial
- Development organization's resource requirements

Figure 3-2 shows the estimated acquisition agency labor, in person days, required to

- Implement SCE in program documentation.
- Train SCE team members.
- Conduct the site visits.
- Incorporate the SCE findings into source selection results/decisions.

The estimate assumes a single source selection, a program office having no prior experience with SCE, and three offerors within the competitive range who must be evaluated. For a team of five who conduct three site visits, the total labor is approximately 115 person days. For reference, the estimated labor for an acquisition involving only one site visit is 65 person days (Total Effort Fixed Costs 39.75 person-days plus Variable Cost Effort of 25 person-days for site visit). Certainly, there are economies of scale and there are many non-recurring costs, such as team training, which will continue to reduce overall acquisition agency labor costs as trained resources are utilized on subsequent acquisitions. In an instance where the program manager and SCE team have been trained and have used the method previously, the estimated labor to implement SCE on an acquisition (with three site visits) declines to 83.5 person days. (114.25, less SCE information gathering 5.25, less RFP preparation 1, less SCE Training 25)

This analysis leaves it up to members of the individual program office to determine their own average person cost per day, average travel and per diem costs, and subsequently add these to the cost of team training to estimate a total dollar cost for implementing SCE.

	SCE Effort Phase	Who Does It	Effort days per person	Number of People	Total Effort
Fixed Costs	SCE Information gathering	PM, PCO, SCE team lead	0.25 1.5	3 3	0.75 4.5
	RFP Preparation	SCE team leader or PM	1 1 .5 .5	1 1 1 1	1 1 0.5 0.5
	SCE Training	SCE team members	5	5	25
	SCE Findings Preparation	SCE team members	1	5	5
	Contractor Debriefs	PM, PCO, SCE team leader	0.5	3	1.5
Subtotals			11.25		39.75
Variable Cost	SCE Site Visits 3	SCE team members	5	5	75
Total Person Days Effort					114.75

Figure 3-2 Estimated SCE Labor For One Source Selection

Personnel
Constraints

The largest constraint on the acquisition agency is the labor effort expended by the individuals constituting the SCE team. This team is needed for one full work week for every SCE site visit that is performed. In addition, several person-days are needed to prepare for each site visit and prepare the detailed report or set of findings that is submitted to the management body sponsoring the evaluation.

In addition to the site visit requirements, the SCE team leader or the program office's software focal point will be needed on a part-time basis prior to the site visits to incorporate appropriate language into the source selection materials that are affected by SCE, assemble an SCE team, and schedule training for any untrained team members. This part-time task will be minimal once the respective acquisition organization has put in place support materials for SCE, including this

guide. After the site visits, the SCE team leader will likely be needed to advise the evaluation sponsor and perform outbriefs to the development organizations as directed by his or her PCO. Figure 3-3 shows approximately the distribution of human resources over time.

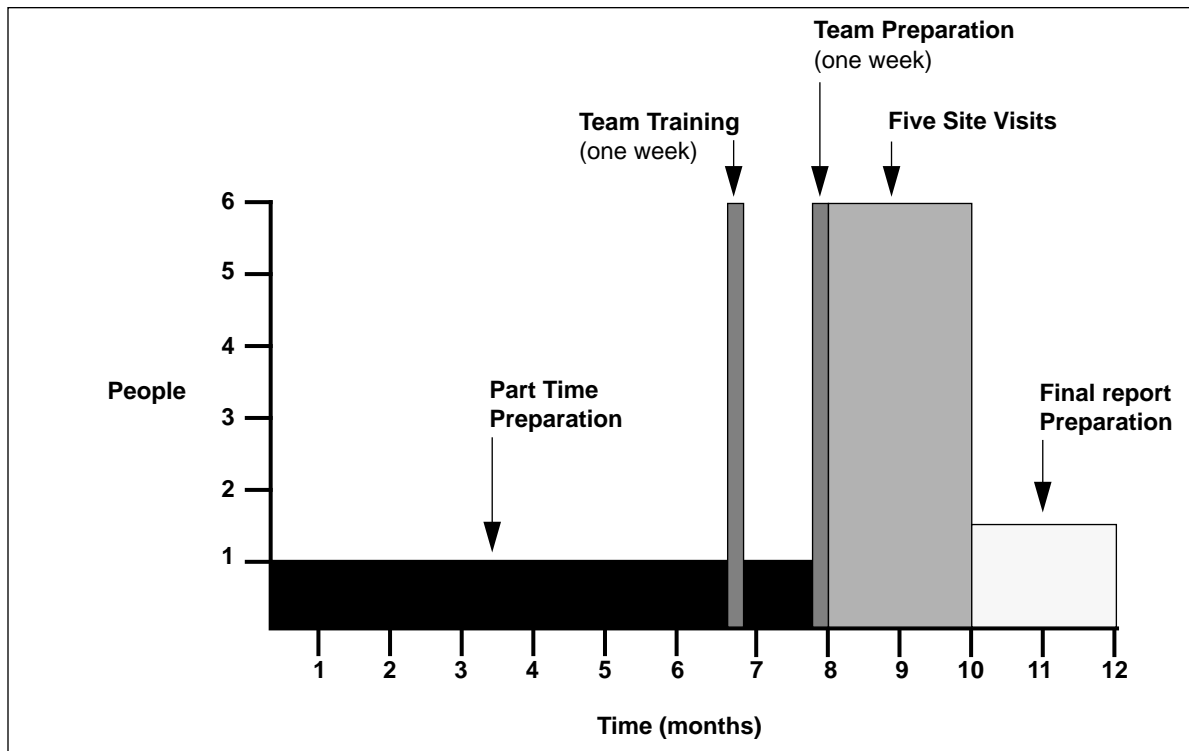

Figure 3-3 SCE Person-Loading Over Time

Time Constraints

The SCE team is needed for at least one and a half weeks for every a site visit. This includes

- Preparation: 1-2 days.
- Travel time: 1 day.
- Site visit: 3 days (includes caucus and findings preparation).
- Time off between site visits: 1 day.

Time off is important because site visits are very intense activities. These resource loading estimates are included in Figure 3-3, above.

Another time constraint is imposed by the typical source selection schedule. Site visits cannot begin until after the initial proposal evaluation and only on those offerors remaining in the competitive range. This typically allows a one to two month window for the conduct of the on site phase of the SCE. A program manager does not know the number of offerors until proposals are received. This means that the program manager will have to estimate how much time is needed to complete all the SCEs based on the estimated number of offerors.

Financial
Constraints

Figure 3-4 presents an actual cost summary, \$61,400 (not including labor cost) from a single acquisition that conducted nine SCE site visits. Another agency estimated the single acquisition cost of using SCE to be as low as \$20,000. The SCE training cost can be amortized over a larger number of SCEs as the individual team members participate on other source selections or acquisitions. The agency as a whole will benefit over time by reducing training costs as the numbers of trained personnel increase and SCE use becomes more routine.

Given a \$10 million acquisition, which was introduced earlier as a reasonable threshold for seriously considering the use of SCE, and a similar number of offerors as shown in Figure 3-4, the SCE cost is 0.6% of the total program cost. While using SCE to help select the most qualified offeror will not eliminate

cost or schedule problems, it will point out the offeror(s) with the best proven practices to mitigate such problems, which can more than pay for itself over the life of the contract.

Itemized Expenses	Unit Costs (1 week)	Total Costs (9 site visits)
Travel Expenses (5 person team)	2,500	22,500
Hotel	1,600	14,400
Per Diem and Miscellaneous	1,500	13,500
One-time Training Course		11,000
Total SCE Costs		\$61,400

Figure 3-4 Example SCE Cost Summary (Training Plus On-site)

Development
Organization
Resource
Requirements

The costs of supporting an SCE are significant—though not always as high as those of the acquisition agency. Considerable preparation time is expended by a company; the company is typically trying to put its best foot forward for the acquisition agency, especially if the SCE is done in conjunction with a source selection. Thus, all development organizations will perform some preparatory tasks to accommodate an SCE.

Figure 3-5 provides an estimate of those costs, using \$200,000 as the cost per person-year or \$3,850 per person-week. The preparation time of four person-weeks accounts for one person full-time for four weeks or two individuals working full-time for two weeks prior to the SCE site visit. Activities

include identifying projects for review, getting maturity questionnaires and project profiles completed, and coordinating the site visit activities.

Itemized Expenses	Cost
Preparation Time (4 person-weeks)	15,400
Site Visit Impact (1 person-week)	3,850
POC and Debriefing Time (3 person-weeks)	11,550
Total Cost	\$30,800

Figure 3-5 Example SCE-Imposed Development Organization Costs

The site visit costs are those associated with conducting individual interviews. The final costs are those produced by the offeror point of contact (POC), who accompanies the SCE team, coordinates activities with the company, and schedules the individuals for interviews. This POC also prepares individuals before each interview and debriefs the interviewee after each interview. These costs vary considerably from organization to organization.

Costs can increase if some contractor staff must travel to another site to accommodate an SCE. Sometimes the projects selected for the evaluation are within a product line and division that may be at different locations. While the SCE Method encourages project selection within the same geographical location, this cannot always be done because of the development organization's organizational make up. Development organization personnel traveling to accommodate an SCE will not only be spending travel funds, their SCE-associated labor costs will be greater as well. Under these circumstances, the SCE team should work with the development organization's POC in an effort to minimize impact on those affected projects.

The development organization's preparatory costs are significant: for a period of at least a week, the offeror's operations will be disrupted by SCE site activities, company

Suggestions For
Optimizing
Resources

preparation, and debriefing activities. These estimated costs will change depending on the contractor, and also as contractor familiarity with the SCE process grows and preparation becomes more standardized.

An excellent way for an acquisition organization to optimize the resources required for SCE implementation is to assign full-time SCE support to acquisitions. This option offers the greatest savings, in both cost and personnel. Full-time support can take on two levels of involvement. Personnel can:

- Help with the source selection documentation needed to use SCE, identify team members, and coordinate their training.
- Augment the SCE teams for specific acquisitions by participating in the on-site visits.

Fully dedicated personnel, who have already gone up an SCE learning curve, should be capable of implementing local SCE policies and procedures quickly and effectively, which should reduce overall costs.

The use of full-time resources to augment a program's SCE team will insure organizational consistency in the practice of the SCE Method, and assist the training of personnel through a form of on-the-job technology transition. Utilizing at least one full-time resource will act as a significant acquisition "force multiplier" when it comes to implementing SCE in an organization.

The following approaches to cost reduction should be avoided under all circumstances because they would *not* follow the SCE Method.

- Site visit time less than three days.
- Teams of fewer than four people.
- Team members untrained.
- Using Maturity Questionnaire responses alone without performing site visits.

- Accepting SPA results in lieu of conducting site visits.

These approaches undermine the consistency, repeatability, and reliability of the SCE Method.

Chapter 4 **Implementing SCE in a Source Selection**

The previous chapter explored issues which are relevant to making the decision to use SCE in an acquisition. This chapter will discuss the issues involved in actually using SCE in the source selection process. The first section discusses the source selection schedule and the implications of using SCE. The next section addresses the options for factoring the SCE findings in the source selection decision.

Scheduling SCE in a Source Selection

This section presents the source selection process using the RFP release point as the date from which to build a source selection schedule. The following subsections will examine the SCE schedule within a source selection before and after RFP release. Each will present a schedule of SCE-related activities showing a range of time in which the activities need to be completed, not the time to complete the activity. These schedules are approximate rather than absolute, and should be tailored to the acquisition's circumstances. Each activity on the schedules is annotated with a comment describing the activity and a number which will be referenced in the text for further discussion of each SCE-related activity.

SCE Schedule Leading Up To RFP Release

The schedule presented in Figure 4-1 refers to the major SCE-related source selection activities that are typically accomplished before the release of the RFP. The first three activities—annotated with a “1,” “2,” and “3”—show start dates in the range of seven or eight months prior to the release of the RFP. Depending on the acquisition, these dates could be too close or too far from the target RFP release date. Activities 2 through 5 are explored in more detail in Chapter 5.

Activity 1—SCE Implementation Planning. This is the activity discussed in Chapter 3—deciding to use SCE in an acquisition. This activity could continue until the day the proposals are received, depending upon the proposed

application of SCE. Part of the activity may include inserting wording about planned SCE usage into the Commerce Business Daily (CBD) announcement. This activity starts before the formation of an SCE team.

Activities 2 and 3—Documentation. This activity involves preparing the documentation needed for the Source Selection Plan (SSP) and the RFP. These documents describe how SCE will be used for the acquisition—the former for the SSA, SSAC and SSEB, the latter for the offeror community.

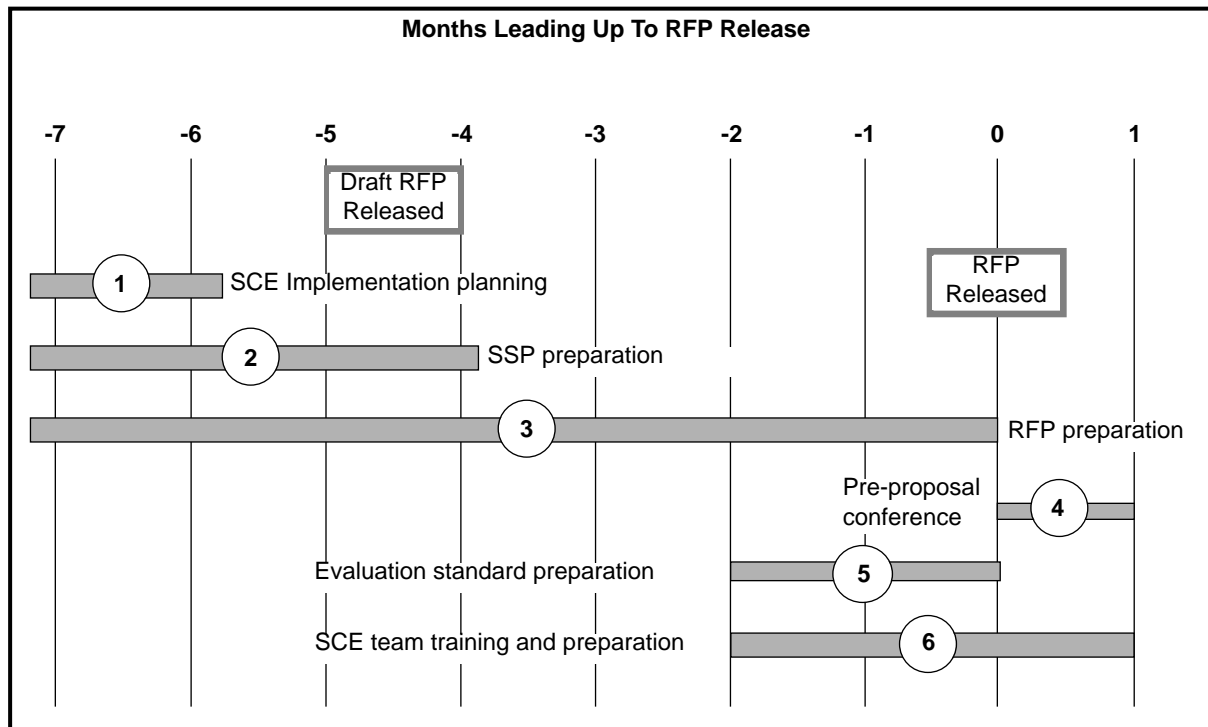

Figure 4-1 Sample SCE Schedule Leading Up To RFP Release

Activity 4—Pre-Proposal Conference. This is usually a one-day event to present the acquisition strategy, contract type, evaluation criteria, and major program milestones to prospective offerors. It is an opportunity for the offeror community to hear first-hand about the pending program and for the government to receive feedback on the program and their source selection approach. Typically, a portion of the

event will be dedicated to briefing how SCE will be used, and allowing offerors to seek further guidance or explanation, if needed.

Activity 5—Evaluation Standard Preparation. This activity is one of the most important activities the SCE team leader or other individual responsible will be engaged in related to SCE. The evaluation standard will dictate to the government team how the SCE site visit strengths and weaknesses by key process area are measured and then translated into findings used in the source selection decision. Standards are not provided to the offerors.

Activity 6—SCE Team Training and Preparation. This activity will vary in amount of work according to the experience of the team and the SCE infrastructure in place at the acquisition organization that supports the team. It is recommended that team training take place within one to two months of the actual site visits. If all members of the team have been trained, but have not worked together on an SCE, a practice SCE is recommended. All team members should have been trained in SCE by the SEI, which is the only official source of training at this time.

SCE Schedule After
RFP Release

Figure 4-2 depicts a typical source selection schedule after RFP release. As with previous schedules, this one is given for illustrative purposes only.

Activity 1—Offerors Prepare Proposals. Within the acquisition organization, while offerors are preparing proposals, the month after the RFP has been released is spent preparing for SCE site visits. During this period, the SCE team should come together to prepare for the site visits, including team-building activities. The offerors will have received instructions in the RFP on exactly how to prepare for the possibility of SCE site visits. This will have included specifics regarding project selection, responding to the maturity questionnaire, and establishing a point of contact who will help with the logistics of the site visit.

Activity 2—Initial Evaluations. After receipt of the proposals, the technical, cost, and past performance PRAG or other evaluation teams begin their activities. The SCE team is typically part of the technical team and may also evaluate written proposals in software area(s). The receipt of proposals is typically the initiation of the formal preparation for on-site visits to the offerors; however, the visits themselves will not be conducted until after the competitive range determination is made. The particular circumstances of the acquisition (e.g. number of offerors, SCE team availability, competitive range determination) will dictate the exact activities that occur for the SCE team during this period of time.

Activity 3—SCE Site Visits. The SCE team will perform site visits with all the offerors remaining in the competitive range. Precisely when the SCEs are to be conducted is largely dictated by how SCE is being used in contributing to the source selection decision as described in the SSP or evaluation plan. For instance, if the SCE results will be factored into an item or items of specific criteria, they should be conducted after receipt of change requests (CRs) or deficiency reports (DRs) but before face-to-face discussions. If SCE is to be used to support PRAG (past performance) findings, then site visits can be accomplished anytime after competitive range determination but before best and final offers (BAFOs) are issued.

Activity 4—Discussions / Negotiations. This activity addresses that part of the process where CRs, DRs, and Points For Negotiation (PFNs) are communicated to the offerors within the competitive range. These tools can be used by the government to communicate SCE findings to the offerors. The government allows all remaining offerors to respond to each and then requests these offerors to submit a BAFO. The government will also begin developing “model” contracts for those offerors still within the competitive range to reflect the terms and conditions agreed upon by both parties (the government and that particular offeror). Offerors are advised that any deviation from the agreed-to terms and conditions

that are not traceable from their original proposal may result in their proposal being unacceptable. This period, too, can last more or less time than depicted in Figure 4-2.

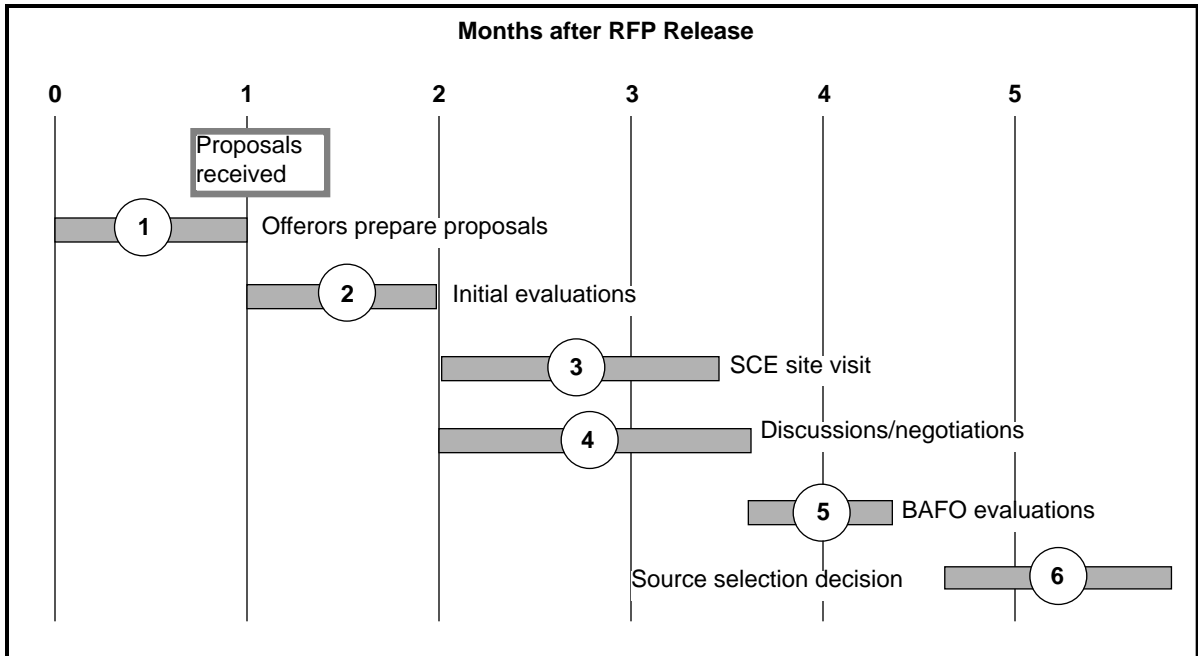

Figure 4-2 Sample SCE Schedule After RFP Release

Activity 5—BAFO Evaluations. Here, the government considers the offerors' BAFOs. This may entail significant analysis comparing the offeror's responses as to their effect upon the analysis and determinations formulated up to this point. Here again the new or revised information is analyzed/evaluated against the approved evaluation standards used in evaluating the offerors initial proposal.

Activity 6—Source Selection Decision. Once all of the aforementioned activities have been completed, an award decision will be made. The SSA will have been convinced that an equitable, effective and objective evaluation of each offeror's strengths, weaknesses, and improvement activities has been made by the SSEB/T. The time from receipt of BAFOs to contract award can take some time as there are a considerable number of legally imposed actions that must take place before announcing an award.

**Using SCE
Results in the
Source
Selection**

This section explores using the findings from an SCE site visit in the final decision of a source selection. Section M of the RFP notifies offerors that the use of SCE would be evaluated as a specific criterion. Included in this section will be an example using a color code scheme as the rating tool in the source selection process. The discussions that follow, while using data from real acquisitions, have been edited to eliminate source selection sensitivity or to illustrate a key point about SCE implementation. A reference to the PRAG is included at the end of this section. SCE findings would be incorporated into the performance risk assessment report/briefing if SCE is used as part of PRAG activities.

There is a significant difference between specific criteria and performance risk assessments. The source selection-related regulations, regardless of the implementing agency, require that specific criteria encompass the characteristics of the program being acquired. All acquisition agencies require the establishment of order of precedence for the various specific criteria, so that the offerors understand their relative importance and can craft their proposal accordingly.

Additionally, pre-established standards of evaluation are prepared for each criterion and the offerors' proposal is measured against those standards by the SSEB. This evaluation against the evaluation standards then forms the basis of comparison of one proposal to another, which is done in a source selection, typically by a more senior body, such as the Source Selection Advisory Council.

Note that in developing any evaluation standards (Figure 4-4 and Figure 4-5), the appropriate procurement regulations should be followed as well as consulting and working with the source selection staffs.

To get the most emphasis of SCE use in source selection, SCE should be used as a specific criterion and may also be evaluated by the PRAG for performance risk. Use of SCE results as specific criterion and/or in the PRAG for

performance risk will be decided by the SSA at the same time the SSP is approved, based on source selection regulations and program requirements.

Using SCE as a Specific Criterion For Award

Each offeror's proposal will be evaluated against the following areas listed in descending order of importance (list areas in descending order of importance or specify relative importance. Note: Areas should be limited to two [including cost/price], when feasible).

The technical area (or each of the areas [except cost/price] if more than two areas used) will be rated in three ways:

1. A color/adjectival rating.
2. A proposal risk rating.
3. A performance risk rating.

The color/adjectival rating depicts how well the offeror's proposal meets the evaluation standards and solicitation requirements. Proposal risk assesses the risk associated with the offeror's proposed approach as it relates to accomplishing the requirements of this solicitation. Performance risk assesses the probability of the offeror successfully accomplishing the proposed effort based on the offeror's demonstrated present and past performance. The government will conduct a performance risk assessment based on the offeror's relevant present and past performance. In assessing this risk, the government will use performance data to evaluate the areas listed above.

Offerors are to note that in conducting the performance risk assessment, the government will use both data provided by the offeror and data obtained from other sources. Within each area (other than cost/price), each of the three ratings—color/adjectival, proposal risk, and performance risk—will be considered in making an integrated source selection decision as to which proposal is most advantageous to the government.

SCE should be used as an item under an area of specific criterion such as Technical/Management and/or in the PRAG for performance risk assessments. Ultimately, how SCE findings are translated into SCE results and used in the Source Selection (SS) should be determined by the SSA based on source selection regulations and program requirements. Figure 4-3 provides an illustration from an acquisition employing SCE as a technical item (software engineering capability) in the technical area.

Technical Area	Description
Software Engineering Capability Item	The acquisition organization will evaluate the offeror's software process by reviewing its Software Process Improvement Plan (SPIP) and by conducting an on-site visit using the Software Engineering Institute- (SEI) developed Software Capability Evaluation (SCE) Method.
Technical Approach Item	The government will evaluate the offeror's technical approach to accomplishing the... tasks. The evaluation will assess the extent that the approach satisfies the objective, goals, and requirements of the Statement of Work.
Management Item	The acquisition organization will evaluate the offeror's management approach to accomplish contract goals and the extent to which the approach achieves the objectives, goals, and requirements of the solicitation. The government will focus on...

Figure 4-3 Sample Set of Specific Criteria or Technical Items

What follows is an example using SCE as a specific criterion in making the source selection decision. The specific needs of the acquisition should dictate the exact approach to be used. In this example, the items of the technical area are listed in descending order of importance. This example is but one approach and method for implementing SCE findings in the source selection decision.

This example continues the discussion of SCE as a specific criterion as depicted in Figure 4-3. The example will illustrate the incorporation of the SCE findings into the various source

Color Coding the
Technical Items

selection evaluation tools/documents that are used for the source selection as well as the definitions established for the various color ratings and the identification of risk.

Applying color codes begins when the SCE team has completed all site visits and the evaluations of the offerors' Software Process Improvement Plans (SPIP). In this example the SPIP was requested to be prepared and submitted separately at the same time the proposal was submitted.

Using this approach, each technical item is assigned a color which corresponds to a rating—from “exceptional” to “unacceptable.” For each item, an evaluation standard is written to define precisely what an offeror must do to be assigned a certain color.

Figure 4-4 shows how colors were used and how ratings such as “exceptional” were defined [USAF 88].

Color	Rating	Definition
Blue (B)	Exceptional	Exceeds specified performance of capability in a beneficial way to the government. Has high probability of satisfying the requirement. Has no significant weakness.
Green (G)	Acceptable	Meets evaluation standards. Has good probability of satisfying the requirement. Any weakness can be readily corrected.
Yellow (Y)	Marginal	Fails to meet evaluation standards or has low probability of meeting the requirement; or has significant but correctable deficiencies.
Red (R)	Unacceptable	Fails to meet a minimum requirement. Deficiency requires a major revision to correct.

Figure 4-4 Description of Colors

Along with each color, the evaluation team assigns a risk rating which reflects the risk associated with the offeror performing on time, within budget, and within the specified performance parameters. Figure 4-5 lists the ratings and their definitions. This example used the consistency between the

SCE findings and the achievability of the offeror's software process improvement program to denote the risk of the item, Software Engineering Capability.

Risk	Definition
High (H)	Likely to cause significant serious disruption of schedule. Increase in cost, or degradation of performance even with special contractor emphasis and close government monitoring.
Moderate (M)	Can potentially cause some disruption of schedule, increase in cost, or degradation of performance. However, special contractor emphasis and close government monitoring will probably be able to overcome difficulties.
Low (L)	Has little potential to cause disruption of schedule, increase in cost, or degradation of performance. Normal contractor emphasis and government monitoring will probably be able to overcome difficulties.

Figure 4-5 Description of Risks

A complete set of offeror findings (strengths and weaknesses) measured against the CMM KPAs, should be used in assigning color codes and risks. The SCE team should provide the SSEB with these findings. See Figure 4-6, Figure 4-7, and Figure 4-8 for an example. (Figure 4-6 is a summary of the findings, while Figure 4-7 and Figure 4-8 show the details of that summary.)

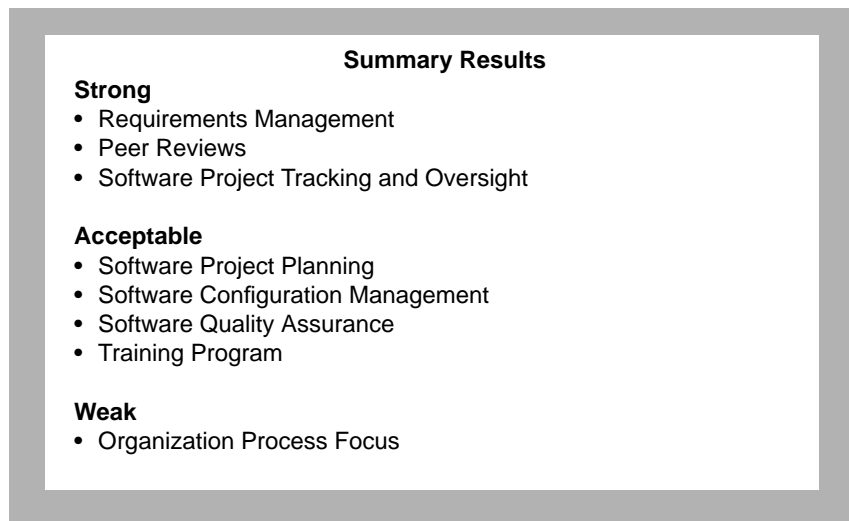

Figure 4-6 Summary Findings From a Recent SCE

The source selection organization should at no time ask for or accept findings from a Software Process Assessment (SPA). As discussed in Chapter 1, SPA findings are determined for a different purpose and are inappropriate for use with SCE findings in a source selection decision.

The summary findings shown in Figure 4-6 reveal that only one key process area was weak. The weaknesses contributing to that determination can be found in Figure 4-7 and Figure 4-8. Although there were weaknesses in other key process areas, only the Organization Process Focus weaknesses were found to be significant enough for that KPA to be included in the summary findings weak area. The details of that determination are made by the SCE team in the context of this specific acquisition. This means that the SCE team used their individual professional judgment to determine the degree of satisfaction of the goals of each KPA. The context of these determinations is critical to the findings. For example, it is possible that an organization may have a software configuration management system that most experienced personnel would consider excellent. However, the SCE team may have found that one project does not use it, another project uses it very effectively, and a third or fourth project

may use it in differing levels of application. This is an example where the SCE team would be faced with determining, from the organizational standpoint, whether a finding for the Software Configuration Management KPA is acceptable, weak or strong. On one hand it was determined that the configuration management system in place is excellent (a strength), on the other hand the evidence suggests spotty implementation and or application (acceptable or weak?). Does this mean the finding is reported as a strength, acceptable or as a weakness? This type of dilemma is typical of those faced by the SCE team for which the various background experience in the different disciplines comes into play in providing consensus from a professional judgment standpoint on specific findings for each KPA investigated.

<p style="text-align: center;">Requirements Management</p> <p>Strengths</p> <ul style="list-style-type: none"> • Effective review/statusing mechanism in place • Very strong, clear lines of authority • Software engineering process represented throughout system engineering process (and vice versa) • Action items tracked to closure by management • Sure technical presence at managerial level <p>Weaknesses none</p> <p>Improvement Activities none noted</p>	<p style="text-align: center;">Peer Reviews</p> <p>Strengths</p> <ul style="list-style-type: none"> • Multiple, rigorous requirements, design, and code inspections conducted • Training required to participate on peer reviews • Experienced, senior people lead reviews • Currently tracing defects and beginning to analyze results <p>Weaknesses</p> <ul style="list-style-type: none"> • Lack of organizational consistency in the reviews of each phase <p>Improvement Activities none noted</p>
<p style="text-align: center;">Software Project Tracking and Oversight</p> <p>Strengths</p> <ul style="list-style-type: none"> • Provides wide coverage of software process at a detailed level • Extensive use of programmers' notebooks to guide staff through various phases of the process • Emphasis on populating useful software development folders <p>Weaknesses</p> <ul style="list-style-type: none"> • Lack of organizational consistency <p>Improvement Activities none noted</p>	<p style="text-align: center;">Software Quality Assurance</p> <p>Strengths</p> <ul style="list-style-type: none"> • Experienced personnel • Very good relationship with development personnel • Independent reporting chain <p>Weaknesses</p> <ul style="list-style-type: none"> • Lack of sampling mechanism • Lack of independent audit coverage and depth • Resources lacking on some projects <p>Improvement Activities</p> <ul style="list-style-type: none"> • Establishing an independent reporting chain • Interviewing for SQA personnel

Figure 4-7 Detailed Findings

<p style="text-align: center;">Software Project Planning</p> <p>Strengths</p> <ul style="list-style-type: none"> • Procedure for sizing and costing of software exists project to project • Extensive collection of management metrics and tracking of progress • Schedule and performance based on real progress • Cost and schedule consistent with size <p>Weaknesses</p> <ul style="list-style-type: none"> • Inconsistent sizing procedure across organization • Lack of completely written sizing procedure <p>Improvement Activities none noted</p>	<p style="text-align: center;">S/W Configuration Management</p> <p>Strengths</p> <ul style="list-style-type: none"> • Effective change control process • Automated tool to enforce change control process • Effective traceability between development products <p>Weaknesses</p> <ul style="list-style-type: none"> • Lack of mechanism insuring the adequacy of regression testing <p>Improvement Activities none noted</p>
<p style="text-align: center;">Training Program</p> <p>Strengths</p> <ul style="list-style-type: none"> • Training database by individual exists • Many diverse courses offered • Individualized training program updated during yearly appraisal <p>Weaknesses</p> <ul style="list-style-type: none"> • Training program inconsistently implemented and emphasized across the organization • Inadequate resources to ensure timely training <p>Improvement Activities none noted</p>	<p style="text-align: center;">Organization Process Focus</p> <p>Strengths</p> <ul style="list-style-type: none"> • Organizational function exists • Full-time resources in place • Organizational focus for metrics collection <p>Weaknesses</p> <ul style="list-style-type: none"> • Lack of buy-in from the engineering staff (many unaware of existence) • Lack of SEPG focus and record of accomplishment <p>Improvement Activities none noted</p>

Figure 4-8 Detailed Findings (continued)

Another aspect of using SCE is illustrated by the use of PFNs to communicate software process weaknesses identified by SCE to the offerors within the competitive range. A CR should be used to communicate a weakness initially. A PFN can be used to identify those points the government wishes to discuss further. A PFN or CR will never be used to identify a deficiency. The SSEB then considers their responses with the original SCE findings before making a final determination against the evaluation standard. This approach allows the offerors the opportunity to point out any oversights on the part of the SCE team. The SCE team could prepare a PFN (or

CR if appropriate) to let offerors know what weaknesses were found. Figure 4-9 is an example of a PFN. This example details the specific weaknesses found by the SCE team that made the KPA Organization Process Focus weak.

Source Selection Information (See FAR 3.104) For Official Use Only (when filled in)	
POINT FOR NEGOTIATION	
Government Reference: IFPP Paragraph 3.3.4	Offeror: XYZ Corporation
Offeror Reference:	Register Number: PFN-XYZ-S-001
<p>Point for Negotiation:</p> <p>The key process area (KPA) found by the Software Capability Evaluation (SCE) to be weak is Organization Process Focus. The detailed findings leading to this conclusion are as follows:</p> <ul style="list-style-type: none"> • Lack of buy in from the engineering staff (many unaware of existence) • Lack of SEPG focus and record of accomplishment 	
SCE team Chief:	SSEB/T Chairperson:
Source Selection Information (See FAR 3.104) For Official Use Only (when filled in)	

Figure 4-9 Findings Incorporated Into a Point For Negotiation (PFN)

The findings that go into a PFN may vary. One acquisition organization's approach was to provide only those weaknesses in the PFN that caused an entire key process area to be evaluated as weak (as in Figure 4-6). Those are significant weaknesses which, depending upon the affected key process area, may influence the evaluation standard one way or another. Alternatively, the entire findings set may be communicated in the PFN. In deciding what to include in the

PFN/CR, the SCE team leader should work very closely with the PCO, SSEB chairperson, and the acquisition organization's legal advisor.

A PFN/CR is a way to communicate an SCE weakness(es) to an offeror and allow the offeror to respond with one of the following:

- Evidence showing the government's SCE team made an oversight.
- A response accepting the findings.
- A response accepting the findings and identifying improvement activities to remedy the weaknesses.
- A combination of the above previous responses.

A cover letter sent with the PFNs/CRs will explain how the offeror may respond. It is recommended that the letter include a page limitation for the offeror's response so that the SSEB is provided with only relevant evidence.

When the responses to the PFNs/CRs have been received from the offerors (typically five to seven days are allowed for responses) the SCE team leader should analyze them to see if material changes in the findings are required that would necessitate recalling the SCE team. The only time the SCE team would reverse a decision on a finding, is if the offeror shows proof that the team overlooked something.

The SCE team performs an analysis and makes any final adjustments to the findings. These findings will be factored into the technical area/item evaluation results for each offeror. The manner in which SCE findings/results are factored into the source selection results depends upon how SCE was structured into the source selection (e.g. items, factors etc.). Your PCO and procurement regulations will guide you through this step. Figure 4-10 and Figure 4-11 provide an example item summary for the set of findings shown in Figure 4-6, Figure 4-7, and Figure 4-8. The example assumes that no changes to the findings were made during the PFN/CR process.

The item summary contains the color rating and associated risk for the respective offer, some background on the projects the SCE evaluated, the summary and detailed findings made by the SCE team while on site, and a statement justifying the assigned risk. In order to determine the color rating, the SCE team applied the findings to the evaluation standard.

Similarly, for this example, the risk was assigned based upon consistency between the offeror's communicated capability found in the SPIP and the actual SCE findings. In this example, the offeror was rated blue with a low risk. The item summary then points out the various strengths and weaknesses in their appropriate location and justifies the risk rating.

At this level of evaluation, within the SSEB, the offerors are only compared to a pre-established standard. No offerors are compared to one another.

Source Selection Information (See FAR 3.104) — For Official Use Only (When Filled in)			
Item Summary			
Area: Technical	Item: T3/Software Engineering Capability	Offeror: XYZ Corp	Color Rating: Blue
<p>Description of Proposal</p> <p>The offeror proposed a software PIP which...</p> <p>The software Process Improvement Plan was found to be consistent with the SCE findings. The offeror's program of software process improvement is genuine, with considerable emphasis on organizational standardization and removal of defects through rigorous reviews. The projects examined as part of the Software Capability Evaluation (SCE) are as follows:</p> <ul style="list-style-type: none"> • ABCD • HAVE GOLD PLATE • COBRA LIBRARY • CCXYZ 			
<p>Strengths</p> <p><i>Requirements Management</i></p> <ul style="list-style-type: none"> • Defined review/status mechanism in place • Very clear, strong lines of authority • Software engineering represented throughout system engineering process (and vice versa) • Action items tracked to closure by management • Sure technical presence at management level <p><i>Software Project Tracking and Oversight</i></p> <ul style="list-style-type: none"> • Provides wide coverage of software process at a detailed level • Extensive use of programmers notebooks to guide staff through phases of the process • Firm emphasis on populating useful software development folders <p><i>Peer Reviews</i></p> <ul style="list-style-type: none"> • Multiple, rigorous requirements, design, and code inspections conducted • Training required to participate on peer reviews • Experienced, senior people lead reviews • Currently tracking defects and beginning to analyze results 			
Item Chief Signature:		Area Chief Signature:	

Figure 4-10 Findings Incorporated in Item Summary

<p>Acceptable Points</p> <p><i>SQA</i></p> <ul style="list-style-type: none"> • Experienced personnel and independent reporting chain <p><i>Software Project Planning</i></p> <ul style="list-style-type: none"> • Procedure for sizing and costing software exist project to project • Extensive collection of management metrics and tracking of progress <p><i>SCM</i></p> <ul style="list-style-type: none"> • Effective change control process and traceability between development projects <p><i>Training Program</i></p> <ul style="list-style-type: none"> • Solid emphasis from management and extensive in-house software courses • SEPG • An organizational function exists with full-time resources in place <p>Weaknesses</p> <p>The Key Process Area found by the Software Capability Evaluation to be weak was:</p> <p><i>Organization Process Focus</i></p> <ul style="list-style-type: none"> • Lack of buy-in from the engineering staff (many unaware of existence) • Lack of SEPG focus and record of accomplishment
<p><i>Overall Risk Assessment and Evaluation Summary</i></p> <p>Low Risk: The consistency between their SCE findings and software process improvement plan shows they understand their current maturity level and where they are going as an organization. They are very strong technically (very close to being strong in all the key process areas) and are committed to developing quality software using a continually improving development process. This contractor's commitment to process improvement was further evidenced by the process rigor in place on one of their commercial programs where no development standards were required. Their process was still the same and management exercised the same controls.</p>

Figure 4-11 Findings Incorporated in Item Summary (continued)

Item Summaries are reviewed by the SSEB/T chairperson and then an area summary is prepared which normally “rolls up” all (or most) of the strengths and weaknesses from the individual item summaries and then identifies an overall risk for that area. This information is reviewed by the PCO, legal representatives, and the SSAC. The legal and PCO review will examine everything to insure that the evaluation standards have been consistently applied and that the item and area summaries contain consistent types and levels of information. The SSEB/T will present this information to the SSAC. The

SSAC members will analyze the SSEB/T's evaluation results and start the process of comparing each offerors strengths, weaknesses and risk—an activity the SSEB is not allowed to do.

In parallel, the SSEB will make a formal presentation to the SSAC outlining the color codes, strengths, weaknesses and risks for each offeror for each item and area resulting from their evaluations. During this presentation, the SCE team leader, as a member of the SSEB, should be prepared to elaborate on any of the findings from any of the offerors. For example, the SCE team leader should be prepared to explain not only why an offeror was weak in software configuration management, but also why the SCE team found their change control process lacking. The SSAC will want to ensure that the SSEB can substantiate their findings with documented evidence.

At this point in the source selection process, the SSAC, after completing their comparative analysis of all final proposals' strengths, weaknesses and risks, may elect to assign a different color code separate from the SSEB or it may ask the SSEB to reconsider its color codes in light of information discussed in the SSAC briefing. These actions are normally done on an "exception" basis and are not common since the SSAC would have reviewed this material at the time of competitive range and before BAFOs were issued; therefore, any "disconnects" should be resolved before BAFOs are received. Unless an offeror completely changes its proposal approach, there should be no "surprises" in the BAFOs. The SSAC will ensure that the evaluation for each criterion has been consistently and fairly applied to all offerors.

Figure 4-12 shows one way the findings from a series of SCEs has been presented formally to a SSAC. Each offeror's technical rating, strengths and weaknesses, risk, and a summary explaining the basis for the risk are identified and placed next to the other offerors so that the SSAC may compare and discuss them during a presentation. This normally represents the lowest level of detail presented to the

SSAC during the formal presentation. It is during this presentation that an SCE team leader may have to articulate why certain key process areas were a strength or weakness for a particular offeror. The expertise of the SCE team leader is needed to communicate why a KPA was strong or weak and its significance within the software process.

Item: T-3 Software Engineering Capability			
	Offeror A	Offeror B	Offeror C
	Blue	Yellow	Yellow
Strength	<ul style="list-style-type: none"> Requirements Management Peer Reviews Software Project Tracking and oversight 	<ul style="list-style-type: none"> None 	<ul style="list-style-type: none"> Organization Process Focus
Weakness	<ul style="list-style-type: none"> Software Engineering Process Group Organization Process Focus 	<ul style="list-style-type: none"> Software Quality Assurance Training Program 	<ul style="list-style-type: none"> Peer Reviews Software Project Tracking and Oversight Training Program
Risk	<p>Offeror is very strong technically and is committed to developing quality software using a continuously improving development process</p>	<p>Because of the large disparity between SCE findings and their submitted SPIP, it is highly questionable whether the software process improvement is being implemented</p>	<p>Offer's SPIP indicated they are at the initial maturity level with their best practices being applied to all new programs</p>
	L	H	M

Figure 4-12 Findings Output From the Evaluation Standard

The SCE written report must also back up and provide substantiation or articulate reasons for the ratings' assigned since the briefing is reduced to "bullets" only and should be derived from the detailed written findings.

Figure 4-12 illustrates how risk was assigned to the software engineering capability technical score (color rating) in a recent source selection. Note that Offerors B and C have yellow as their technical score, but Offeror B has a high risk and Offeror C has a moderate risk; yet Offeror C has three weak Key Process Areas and Offeror B has only two. How did this occur?

Risk in this acquisition was assigned based upon the consistency of the organization's process improvement program and the SCE findings, because it was stated clearly in the RFP for this acquisition that an organization could be at the Initial maturity level and still be awarded the contract. It was also stated in the Instructions for Proposal Preparation (IFPP) that risk would be used as a measure of an organization's process improvement realism. If an organization had a realistic program of software process improvement, then they were considered low risk, regardless of their current maturity level rating. If an offeror claimed to be at the Defined or Managed maturity level in its SPIP, but the SCE findings showed the offeror to be at the Initial or Repeatable maturity level, then the SSEB would assign either a high or moderate risk. This assignment depended upon the magnitude of the disparity between the SPIP and the SCE findings.

Offeror B had identified itself as being at the Defined maturity level and did not have an improvement plan that would substantiate its progress through the lower maturity level. The SSEB/SCE team determined Offeror B to be closer to the Initial maturity level. In short, Offeror B was unaware of its actual lower maturity level and was consequently assigned a high risk with only two weak key process areas, while Offeror C received a moderate risk with three. Offeror C, on the other hand, had a realistic SPIP indicating it was at the Initial maturity level with its best practices being applied to all new programs. The SCE findings confirmed this and resulted in assigning a lower risk to this offeror.

		Area: Technical		
		Offeror A	Offeror B	Offeror C
Software Engineering Capability	Color	Blue	Yellow	Yellow
	Risk	L	H	M
Technical App.	Color	Green	Yellow	Blue
	Risk	L	L	L
Management	Color	Green	Green	Blue
	Risk	L	L	L
SUMMARY RESULTS	Color	Green	Yellow	Green
	Risk	L	H	M

Figure 4-13 Technical Area Summary

The last step of the process is the integration of the SCE technical rating and risk factor with those of the other technical items to produce a technical area summary, as shown in Figure 4-13. At this point, the SSAC will integrate the color codes and risk factors into area summaries based upon their own analysis and presents them to the SSA. The SSAC then conducts a comparative analysis of all offerors' strengths, weaknesses and risks as presented by the SSEB/T on these item and area summaries and presents it to the SSA. Note: SSAC does not make written recommendations to the SSA. Note that in this example the items in the Technical Area, Management, Technical Approach and Software Engineering Capability are listed in descending order of importance. This illustration of risk identification and assessment is not the sole method for approaching the risk problem. Acquisitions should tailor the risk assignment to the specific needs of the acquisition.

**Performance
Risk Analysis
Group (PRAG)**

Offerors past and present performance is evaluated by the PRAG. Their results will be presented to the SSA in the form of performance risk.

Performance Risk Assessment Definitions:

High

Significant doubt exists, based on offeror's performance records, that the offeror can perform the proposed effort.

Moderate

Some doubt exists, based on the offeror's performance records, that the offeror can perform the proposed effort.

Low

Little doubt exists, based on the offeror's performance records, that the offeror can perform the proposed effort.

N/A

No performance record identifiable.

Chapter 5

Incorporating SCE into the Relevant Acquisition Documentation

This chapter presents the major documents related to the source selection process affected by the incorporation of SCE. The documents examined in this chapter are: Commerce Business Daily (CBD) announcement, Source Selection Plan (SSP), Pre-proposal Conference presentation, RFP, and the Evaluation Standards. A discussion accompanies each section describing why a particular approach was taken. Each section contains at least one example that can be tailored to the unique needs of the acquisition.

Making the Commerce Business Daily Announcement

Figure 5-1 presents a slightly modified SCE-related portion of an actual CBD announcement. This announcement informed the potential offerors that

- SCE would be performed to identify the offeror's software process capability.
- An offeror's software process capability would be an integral part of the source selection decision.
- The government was linking quality, cost, and schedule performance directly to software process capability.
- The offeror should have a SPIP in place designed to achieve higher maturity levels of the CMM.

The message from the government is that offerors should be implementing process improvement programs to achieve higher levels of process capability and should have a program in place to be a "viable" competitor. The RFP that would

follow a CBD announcement such as that shown in Figure 5-1 could reinforce this concept by requiring the submission of a SPIP as an appendix to the offerors' proposals.

The statement in the CBD, "Contractors' software process capability will be verified by analyzing key process areas (KPAs) through the Defined maturity level, and a demonstrable software process improvement program leading to levels of process capability higher than the current capability" makes it clear that the Defined maturity level is not a contract requirement. Rather, it is a standard by which the evaluation will be conducted, and the source selection will consider. It essentially defines the target process capability, which is the capability the acquirer is seeking for this particular acquisition program.

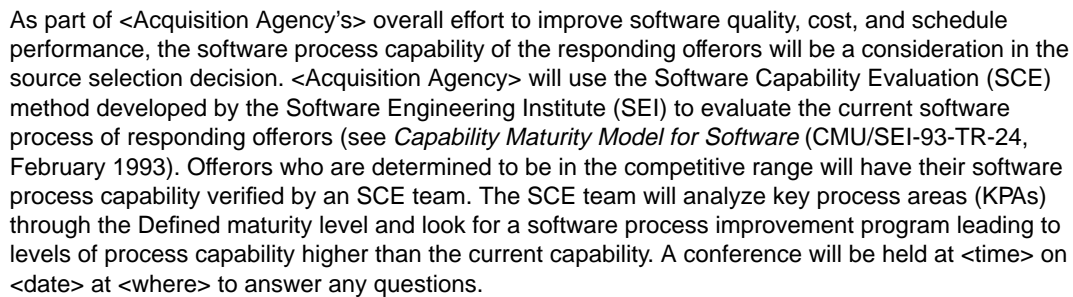
A rectangular text box with a light gray background and a dark gray border. The text inside is a sample CBD announcement paragraph.

As part of <Acquisition Agency's> overall effort to improve software quality, cost, and schedule performance, the software process capability of the responding offerors will be a consideration in the source selection decision. <Acquisition Agency> will use the Software Capability Evaluation (SCE) method developed by the Software Engineering Institute (SEI) to evaluate the current software process of responding offerors (see *Capability Maturity Model for Software* (CMU/SEI-93-TR-24, February 1993). Offerors who are determined to be in the competitive range will have their software process capability verified by an SCE team. The SCE team will analyze key process areas (KPAs) through the Defined maturity level and look for a software process improvement program leading to levels of process capability higher than the current capability. A conference will be held at <time> on <date> at <where> to answer any questions.

Figure 5-1 Sample CBD Announcement

Why place SCE wording into the CBD announcement? SCE is a relatively new technique, and not all offerors will be familiar with it or the government use of SCE. Describing SCE in the CBD allows the acquisition agency to further define requirements so industry has a better understanding of the requirements. The need to place SCE wording into the CBD announcement may diminish in the future after SCE use and process improvement activities become routine business practices throughout the acquisition and software development communities.

Placing SCE in the Source Selection Plan

The Source Selection Plan (SSP) outlines how the source selection will be conducted and subsequently how the award decision will be made. This document is not seen by the offerors. SCE has a relatively small impact on the production of the SSP. SCE is discussed in several places in an SSP. The following subsections address several of these.

Source Screening

In this case, the government would publish a sources-sought synopsis in the CBD requesting that interested offerors provide to the government their qualifications in any one of a number of technical areas important to the acquisition. The purpose of this activity is to produce a list of technically qualified offerors. Maturity level should never be used as a screening criterion at this stage. However, the presence of an ongoing software process improvement program could be used as a screening criterion.

Figure 5-2 provides sample wording to place SCE in the Source Screening section of the SSP. The hypothetical source selection is using Ada Software, Radar Signal Processing, and Software Engineering Capability as screening criteria. The last statement in this example communicates the organization's desire to keep SPA results out of the source selection process. The SCE team should not ask to see SPA results when on site (see Chapter 1 for detail on the differences in the two methods). Many organizations' process improvement programs can be undermined by offerors trying to demonstrate to the government a process capability they cannot support on a new program.

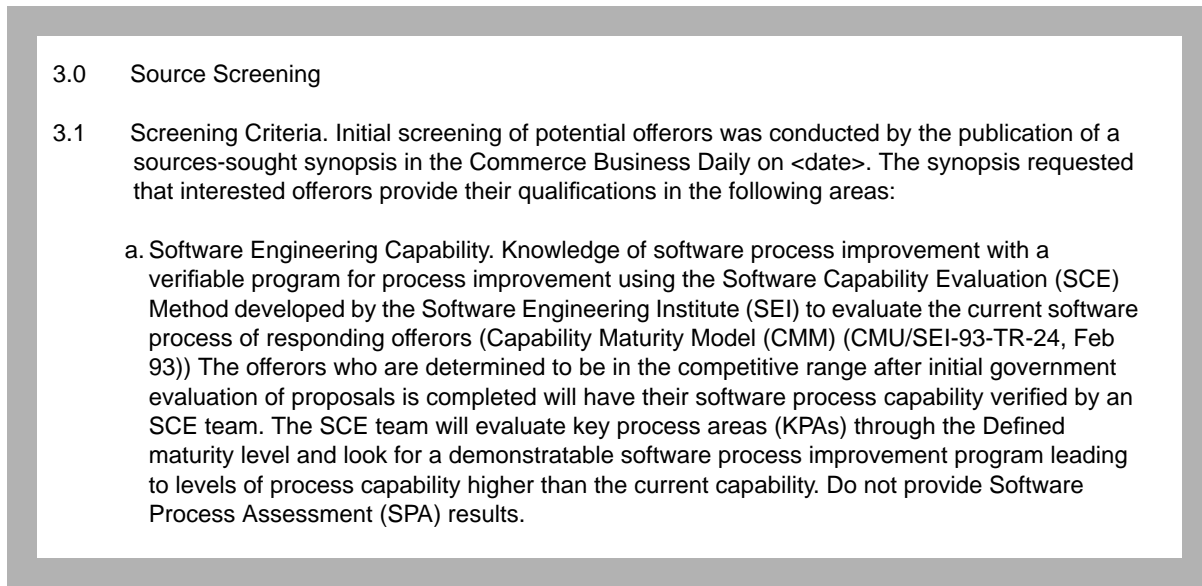

Figure 5-2 SCE as a Screening Criterion in the SSP

SCE as a Specific Criterion

The following example shows how to use SCE as a specific criterion. Keep in mind that this is only an example. Each application of SCE should be tailored to accommodate the unique demands of the acquisition.

Figure 5-3 provides a detailed description of how a source selection could use SCE in the source selection evaluation process.

6.4 Evaluation Criteria

6.4.1 Assessment Criteria

- a. Soundness of approach
- b. Compliance with requirements

6.4.2 Specific Criteria

- a. Technical Area - This area will evaluate three items (Software Engineering Capability (SEC), Technical (TECH) approach, and Management) represented here in descending order of importance:

1. Software Engineering Capability. The government will evaluate the software process by reviewing the offeror's Software Process Improvement Plan (SPIP) and by using the Software Engineering Institute- (SEI) developed Software Capability Evaluation (SCE) Method. The government will determine the software process capability by investigating the Key Process Area (KPAs) defined in the SEI Technical Report, *Capability Maturity Model for Software* (CMU/SEI-93-TR-24, February 1993). The report contains a description of the Capability Maturity Model (CMM). The government will perform an SCE of each offeror remaining in the competitive range by reviewing current projects at the site proposing on this contract and comparing processes used on those projects in the written proposal/SPIP.

The evaluation will result in a composite, substantiated through individual interviews and reviews of documentation, of the offeror's software process on the government-selected projects. A risk assessment to compare proposed practices to current, validated practices may be performed. The evaluation team will determine findings of the offeror's strengths, weaknesses, and improvement activities in all KPAs through the Defined maturity level. Results of the SCE will not be pass/fail. Identified weaknesses will be provided in writing during subsequent discussions. The offeror will be allowed to respond to the findings with a limited number of pages of text. The on-site evaluators may be separate and distinct from the proposal evaluation team and may include a government contracting representative. All evaluators have been trained in the SCE Method.

Figure 5-3 SCE as a Specific Criterion For The SSP

In Figure 5-3, the use of SCE as a specific criterion falls under one of three items under the technical area (SEC, TECH Approach and Management) in this case, SCE is the most important technical item. The SCE findings in this case will form the basis of an item color code and risk assessment and will be compared to an evaluation standard based on the Defined maturity level. The SCE is not pass/fail—that is, being less than Defined maturity level will not exclude an offeror from the competitive range. In this example, all offerors within the competitive range will experience an SCE site visit and be given the opportunity to respond to their

evaluated software process weaknesses through PFNs, CRs, and DR. Complete SCE findings (strengths, etc.) should be provided to each unsuccessful offeror during the post-award debriefings and to the winning contractor at the post-award conference.

What is presented in Figure 5-3 tracks closely with what is presented in a later section of this chapter, “Placing SCE in the Request for Proposal.”

SCE as part of the PRAG

Figure 5-4 shows an example for using SCE findings with a PRAG. Note that in this example the SCE findings are incorporated with other factors into the PRAG analysis.

6-3 Present and past performance (Performance risk)

- (1) Present and past performance is a consideration in all acquisition agency source selections. Performance risk is a structured treatment of present and past performance and will be determined for each area. It is a confidence measure that assesses the offeror's present and past work record in order to determine the offeror's ability to perform the proposed effort. Performance risk is assessed by the Performance Risk Analysis Group (PRAG), which should be chaired by a program manager-level (senior) individual and consist of government personnel. Performance evaluation and risk assessment focus on relevant past performance as it relates to the specific criteria. It is the PRAG's responsibility to analyze the data collected; determine its relevance; and to perform an “independent” risk assessment. The results of the SCE will also be factored into the overall performance risk rating assigned by the PRAG. For information on how to establish a PRAG, how it operates, the forms which are used, and how the evaluation is made and reported, refer to the acquisition agency Source Selection Handbook.

Figure 5-4 SCE as part of the PRAG for SSP

Presenting SCE at the Pre- Proposal Conference

The pre-proposal conference is an important opportunity for the offerors to learn the specific, detailed requirements of the contract and for the government to communicate its intentions and receive feedback from the potential offerors. This section presents a modified sample briefing used during a pre-proposal conference to explain the SCE process and solicit feedback from the prospective offerors. Figure 5-5 provides a title slide and agenda. The presentation consists of the following parts to guide the interaction with the prospective offerors:

- The activities that usually take place in an SCE (Figure 5-6).
- The SCE team process (Figure 5-6).
- A description of validation procedures (Figure 5-6).
- A sample of the documentation that may be looked at by the SCE team (Figure 5-7).
- A sample site visit schedule, (Figure 5-8).
- The CMM and KPAs against which the team will evaluate the offerors (Figure 5-9).
- A sample of the findings the SCE team will produce before leaving the site (Figure 5-10).

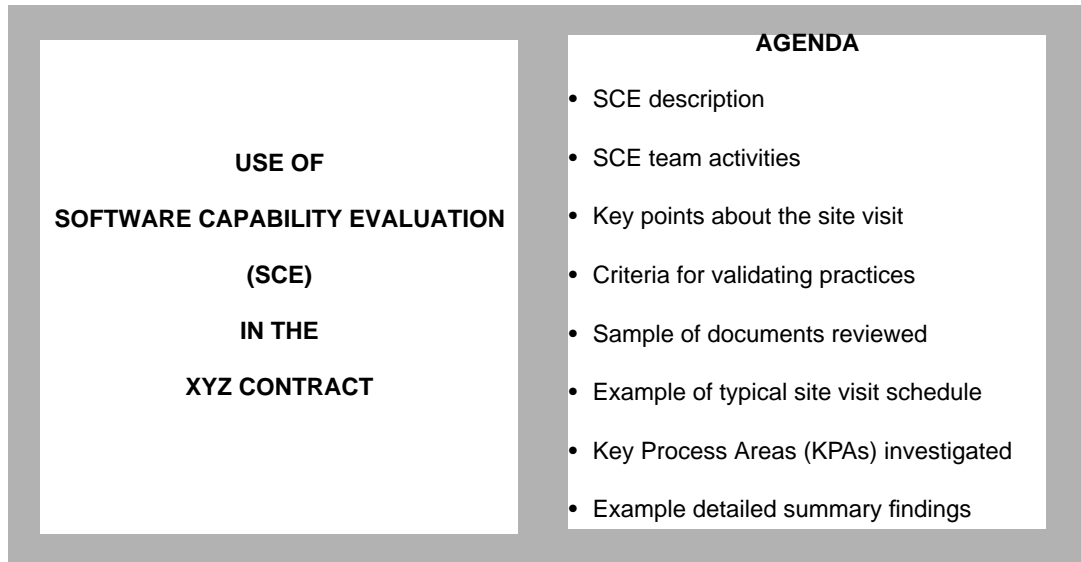

Figure 5-5 Pre-proposal Conference Title and Agenda Slides

Figure 5-6 shows the slides used to describe the SCE Method and give the offeror a feel for the site visit activities. The SCE Method is relatively new in practice and there are offeror locations that have not experienced an SCE. For this reason, it is especially important to take the time to answer any SCE-related questions in an open forum such as an offerors' conference. Emphasis should be placed on how the interviews and document reviews will be conducted.

One of the key differences between the SCE and SPA methods is the examination of documentation to validate the processes. Keep in mind when presenting the slide on validating practices that validation occurs after examining the audit trail information. This audit trail information reveals how certain processes or practices are implemented. The documents which may help describe these practices are listed in Figure 5-7.

<p style="text-align: center;">SCE DESCRIPTION</p> <ul style="list-style-type: none">• A method for evaluating the software process of an organization to gain insight into its software development capability.• Five phase evaluation process using the SEI CMM as the basis for evaluation.• Three-day site visit conducted by a four to six-person evaluation team.• Outcome: findings on process capability in terms of software development key process areas (KPAs)—strengths, weaknesses, and improvement activities.• No recommendations will be made.	<p style="text-align: center;">SCE TEAM ACTIVITIES</p> <ul style="list-style-type: none">• Compare RFP product profile with offeror project profiles to select up to four projects for investigation.• Analyze maturity questionnaire responses.• Set expectations (in-brief) and receive process presentation from contractor.• Interview management and key personnel.• Analyze substantiating documentation.• Produce findings through consensus.
<p style="text-align: center;">KEY POINTS ABOUT THE SCE SITE VISIT</p> <ul style="list-style-type: none">• Team decisions made through consensus.• All interviews confidential.• The SCE team may interview an individual more than once during the same visit.• Interview schedule will become dynamic after the first day.• Interview process works down the chain of command.• Working-level development personnel will be interviewed.• Document review occurs throughout process.• SCE team will not make recommendations.	<p style="text-align: center;">CRITERIA FOR VALIDATING PRACTICES</p> <ul style="list-style-type: none">• Written procedure for a practice exists.• Procedure implementing practice must be effective (work for the organization).• Evidence exists showing track record that procedures are followed.• Practice implemented for at least one year (those less than one year may be listed as improvement activities).

Figure 5-6 Pre-proposal Conference SCE Method Slides

Figure 5-7 provides a broad list of the documentation that the SCE team may examine depending upon the course of the interviews. This list of documents is a guide to better prepare the offerors. Many more documents may actually be reviewed during the site visit. Offerors should be encouraged to obtain the *Software Capability Evaluation Version 2.0 Method Description* [SCE 94] to learn more about the SCE Method.

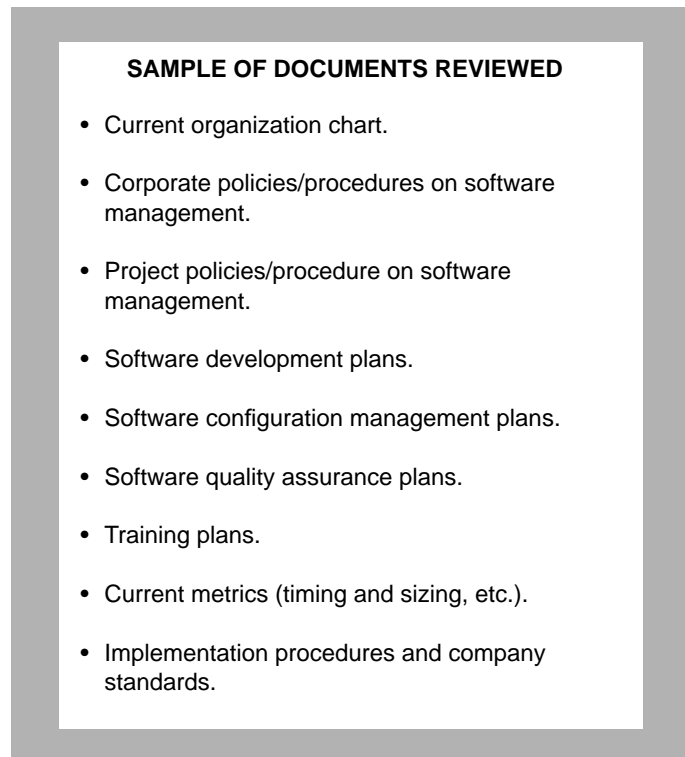

Figure 5-7 Pre-proposal Conference Documentation Slide

The site-visit schedule (Figure 5-8) should be mentioned during the briefing in order to prepare offerors for what will occur during the site visit. It should be emphasized that the SCE team will do everything possible to minimize the impact on the offeror's software development organization.

If the team is planning to visit the engineering floor (software engineer's work areas) at each site, the team should explain how this will be done, should explain that the SCE team will do this activity at a mutually agreeable time during the site visit, and should estimate the duration of the floor visit (normally NTE 4 hours per project visited).

SAMPLE SITE VISIT SCHEDULE	
DAY 0	
0800-1330	Travel for SCE team
1330-1800	Prepare for site visit
DAY 1	
0800-0830	Contractor welcome/introduction and SCE team's orientation briefing
0830-1030	Contractor software presentation/contractor understanding caucus
1030-1230	Initial review of organizational documents
1230-1330	Lunch
1330-1430	SCE team interviews - senior managers
1430-1600	SCE team interviews - program managers
1600-1730	SCE team interviews - software managers
1730-1800	SCE team caucus and requests documents
DAY 2	
0800-1000	SCE team interviews continued with program managers, software managers
1000-1200	SCE team interviews - managers (engineering, SQA, SCM, test, SEPG)
1200-1300	Lunch
1300-1400	SCE team caucus, request and review documents
DAY 3	
0800-1000	SCE team interviews - key personnel (may include engineering staff)
1000-1200	Review additional documentation
1200-1300	Lunch
1300-1500	Additional documentation review and/or additional SCE team interviews - Consolidation interviews with managers, engineers, and staff
1500-1800	SCE team caucus and preparation of findings
DAY 4	
0800-0900	Final preparation of findings
0900-1000	Exit meeting with offeror
1000-1100	SCE team caucus and wrap-up
1100-1730	Travel for SCE team

Figure 5-8 Pre-proposal Conference Site Visit Schedule Slide

The CMM should also be explained so that the basis of the SCE is clear (Figure 5-9). The offerors need to understand what KPAs are going to form the basis of the specific criterion, or be considered under performance risk, incorporating the SCE findings into the source selection decision. Depending upon the offeror pool and their familiarity with the CMM,

additional slides may be needed to explain the subprocess areas or key practices for each KPA the team will be examining during the SCE.

Level	Characteristic	Key Process Area
Optimizing (5)	<ul style="list-style-type: none"> Continuous process improvement capability 	<ul style="list-style-type: none"> Process change management Technology innovation Defect prevention
Managed (4)	<ul style="list-style-type: none"> Product quality planning and tracking of measured software process 	<ul style="list-style-type: none"> Process measurement and analysis Quality management
Defined (3)	<ul style="list-style-type: none"> Life cycle process defined and institutionalized to provide product quality control 	<ul style="list-style-type: none"> Peer Reviews Intergroup coordination Software product engineering Integrated software management Training program Organization process definition Organization process focus
Repeatable (2)	<ul style="list-style-type: none"> Management oversight and tracking of project Stable planning 	<ul style="list-style-type: none"> Software configuration management Software quality assurance Software subcontract management Software project tracking and oversight Software project planning Requirements management
Initial (1)	<ul style="list-style-type: none"> Ad hoc (unpredictable, chaotic) 	

Figure 5-9 Pre-proposal Conference CMM Slide

The last slide (Figure 5-10) in the SCE portion of the offerors' conference briefing explains to the offerors what the results of the site visit will look like and how they will be presented to the SSEB. It is not possible to give specifics on the evaluation standard or the percentage that the technical item Software Engineering Capability contributes to the source selection decision; however, the order of importance SCE has when

used as an item under the technical area can be emphasized. This is an opportunity to reinforce the point that all findings are made through consensus by the team. Sample findings charts should reflect the key process areas that are going to be evaluated for the acquisition.

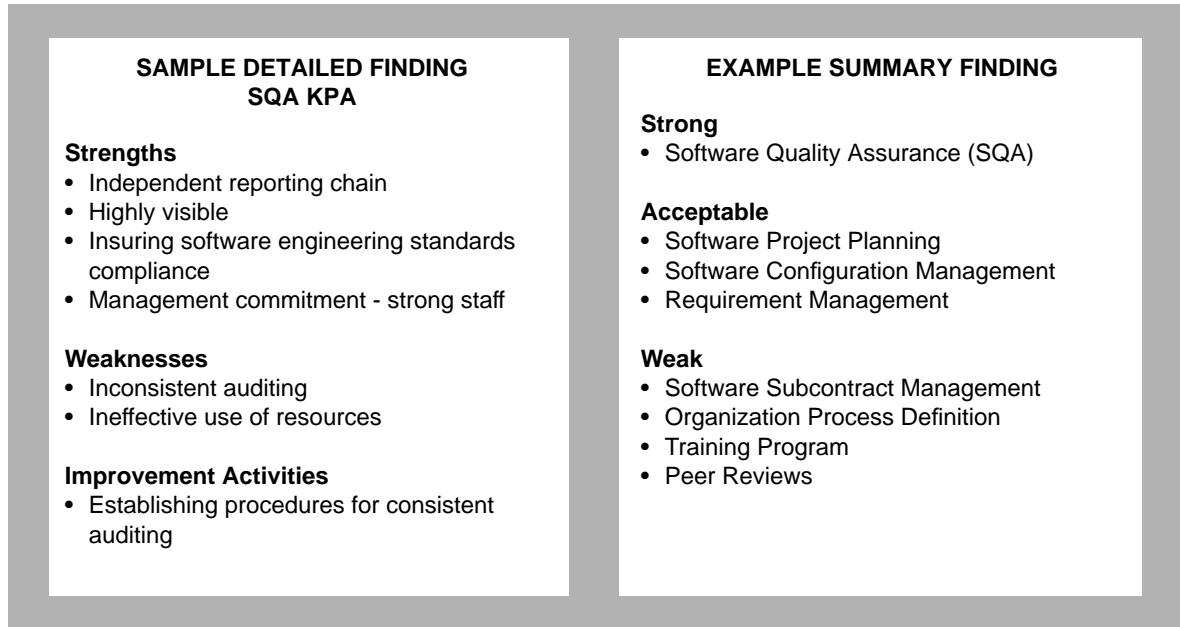

Figure 5-10 Pre-Proposal Conference Sample Findings Slides

Placing SCE in the Request for Proposal

This section contains the information needed to incorporate SCE into the RFP. The RFP is the document used by the government to explain to offerors

- The government's requirements.
- Evaluation criteria.
- The mechanisms that will be employed in making the source selection decision.
- How to propose for the contract.

General Language
for the Request for
Proposal

All of the examples in this section revolve around Software Engineering Capability being used as a specific criterion in the Technical area of the proposal. If the SCE findings are planned to be used as a consideration under performance risk, these examples can be easily tailored to meet such usage.

Regardless of how SCE is to be used in making the source selection decision, the description of its use is found in Section L (Instructions, Conditions, and Notices to Offerors) and M (Evaluation Factors for Award) of the RFP. The example shown in Figure 5-11 closely mirrors an actual description of SCE use found in Section M of an RFP. The example begins by identifying Software Engineering Capability as an item under the technical area (specific criterion).

For this example, there were two areas of evaluation: 1) Technical and 2) Cost. The specific reference to SCE in the RFP begins by describing in general terms

- What will be evaluated in the technical area (process capability) and the importance placed on each.
- What the technical basis of the evaluation is (the CMM KPAs)
- What the results of the evaluation will be (identify strengths, weaknesses, and risk which will also consider improvement activities by KPA)
- How the government will conduct the evaluation (select the projects to be reviewed, conduct interviews, and review documentation).

B. Evaluation Criteria

- 1.0 Introduction
- 2.0 Basis for Contract Award
- 3.0 General Considerations
- 4.0 Assessment Criteria
 - 4.1 Specific Criteria
 - 4.1.1 Technical Area
 - a. Technical Area - This area will evaluate three items (SEC, TECH approach and Management) represented here in descending order of importance:
 - 1. Software Engineering Capability. The government will evaluate the software process by reviewing the offeror's Software Process Improvement Plan (SPIP) and by using the Software Engineering Institute (SEI)-developed Software Capability Evaluation (SCE). The government will determine the software process capability by investigating the Key Process Area (KPAs) defined in the SEI Technical Report, *Capability Maturity Model for Software* (CMU/SEI-93-TR-24). The report contains a description of the Capability Maturity Model (CMM) and the SEI-defined maturity levels. The government will perform an SCE of each offeror remaining in the competitive range by reviewing current projects at the site proposing on this contract and comparing methods/processes used on those projects in the written proposal/SPIP.

The evaluation will result in an organizational composite, substantiated through individual interviews and reviews of documentation, of the offeror's software process activities on the government-selected projects. A risk assessment to compare proposed practices to current, validated practices may be performed. The evaluation team will determine findings of the offeror's strengths, weaknesses, and improvement activities in all KPAs through the Defined maturity level. Results of the SCE will not be pass/fail. Identified weaknesses will be provided in writing during subsequent discussions. The offeror will be allowed to respond to the findings with a limited number of pages of text. The on-site evaluators may be separate and distinct from the proposal evaluation team and may include a government contracting representative. All evaluators have been trained in the SCE Method.

- 4.2 Cost/Price Area...

Figure 5-11 General RFP Language To Include SCE (RFP Section M)

Eliminating
References to
Maturity Levels in
the RFP

While Figure 5-11 treats the maturity level as a basis for evaluation rather than a requirement, it is recommended that references to maturity level be eliminated to the greatest

References to SCE
in the Instructions
for Proposal
Preparation

extent possible. One way to do this is by listing the actual KPAs and subprocess areas or key practices to be evaluated directly in the RFP rather than simply referencing the KPAs found in the CMM. Eliminating references to maturity levels allows the acquirer to establish a target process capability using the CMM KPAs and also to be specific as to the basis of evaluation. It is the findings against the KPAs that are most important to the acquirer in determining specific risk in an offeror, not the maturity level.

The IFPP portion of the RFP informs the offerors how to prepare their proposals and comply with the source selection process. The portion of the IFPP that addresses SCE is divided into five distinct pieces:

1. Organizing the SCE-related information into a separate appendix.
2. Completing the Assessment Recording Forms (Figure 5-12).
3. Completing the Project Profiles (Figure 5-13).
4. Submitting the Software Process Improvement Plan (SPIP) (Figure 5-14).
5. General SCE instructions (Figure 5-15).

Organizing SCE-related Information into an Appendix

Each acquisition must determine the best way for their program to instruct offerors to organize their proposals. The goal is to ease proposal evaluations and obtain concise information wanted, and not to impose a burden on the offerors. Work with your PCO to determine what is best for your acquisition and program. If it is desired that the SCE information be excluded from the technical page limit, you may want offerors to place this information in a separate appendix.

Completing Assessment Recording Forms

One of the more important SCE-related items in the IFPP is the language shown in Figure 5-12 describing how the Assessment Recording Forms are to be completed. The offeror is told to select eight ongoing development efforts that best correlate to the future work under the government's proposed contract, using characteristics such as application domain, software size, development language, etc. to make the best matches.

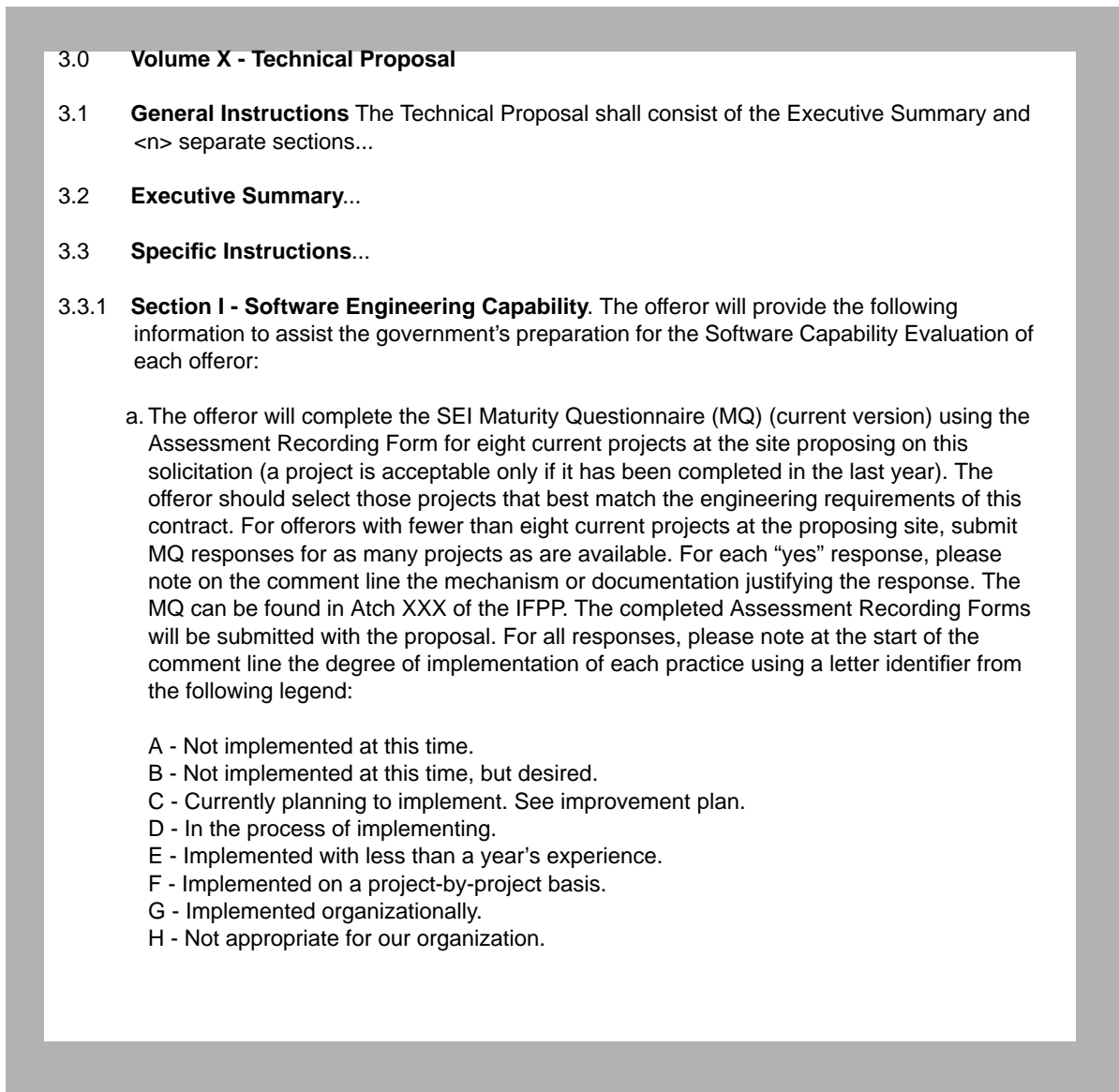

Figure 5-12 Instructions For Completing Assessment Recording Forms

Using the legend in Figure 5-12, the offeror must characterize the state of institutionalization of each practice. To verify each response, the offeror must cite documentation that defines each practice it has characterized. By getting this information from offerors, the SCE team will know more about what to look for to verify a particular software practice, and the

offeror's view of the extent to which a practice is implemented; this will help focus on-site activities (e.g., interviews).

The SCE team wants to identify and separate software practices that are institutionalized (implemented organizationally) from those that are implemented only on a single project. The last reference in Figure 5-12 is to the maturity questionnaires the offeror must complete for each project submitted in order to satisfy this request. The questionnaire should be attached to the RFP so that there is no confusion over which questionnaire the offeror is required to complete (*A Method for Assessing the Software Engineering Capability of Contractors* [Humphrey 87b]).

Completing the Project Profiles

Figure 5-13 directs the offeror to complete a Project Profile for each of the projects selected on the Assessment Recording Form. The project profile provides information such as: size of the organization, application area, development language, type of system, location of development, and the program's current phase(s) of development. This information helps the government in selecting projects for evaluation. A Project Profile should also be included as an attachment to the IFPP.

3.31 (continued)

- b. For each project, the offeror will complete a Project Profile, attach it to the respective Assessment Recording Form, and submit it with the proposal. The Project Profile template can also be found in Atch XXX of the IFPP. This document shall be no greater than one page per project.

Figure 5-13 Instructions For Completing Project Profiles

Preparing the Software Process Improvement Plan

Figure 5-14 addresses the SPIP the offerors submit with their proposals. In the example provided the offeror could not exceed 15 pages of text. This was an arbitrary limit intended to minimize the effort required by the offerors and the

government during the source selection process. The government did not want the offerors to develop an SPIP for the acquisition; rather, they wanted to see plans that were already in place.

3.31 (continued)

- c. The offeror will submit the proposing site's Software Process Improvement Plan (SPIP), in the format of their choosing, with the proposal. The document will be no more than 15 pages. The SPIP should communicate the offeror's current software process capability as well as their desired maturity level, specific planned improvements, dedicated resources, effort estimates, and a time phasing of those improvements to bring the offeror's software process capability to the organization's desired maturity level.

Figure 5-14 Instructions For Submitting the Software Process Improvement Plan (SPIP)

General SCE Instructions

The last set of instructions for the IFPP, found in Figure 5-15, informs the offeror of various SCE-related details that will facilitate a smoothly run SCE with minimal impact on the offeror's organization.

- *An Offeror Point of Contact* is needed so that the SCE team leader may coordinate all activities, both before and during the SCE. Note that the offeror will be notified five working days in advance of the site visit which projects will be evaluated. There are two reasons for this. First, this will give all the offerors the same number of days to prepare for the SCE. Second, because many organizations go to great lengths to prepare for an SCE, giving five working days' notice will limit them from expending valuable resources and time on activities that will have little or no impact on the SCE findings.

3.31 (continued)

- d. After the proposal is received, the government will coordinate a site visit with those offerors remaining in the competitive range to conduct the Software Capability Evaluation (SCE) at the offeror's location. The offeror will provide, with your proposal, a point of contact and phone number at the offeror's site for the SCE team leader to coordinate all SCE activities. The government will also communicate details about the site visit during the coordination process. The offeror will be notified of the projects to be examined approximately five working days prior to the site visit. The site visit dates selected by the government are not open for discussion.
- e. If a site visit is conducted with your firm, the SCE team will need a closed meeting room capable of accommodating at least eight people. The offeror should have a copy of the organization's software standards, procedures and/or operating instructions, and organizational charts for the projects being reviewed in the meeting room when the SCE team arrives. All interviews conducted as part of the SCE will be done in private, one individual at a time.
- f. The Assessment Recording Forms, Project Profiles, and Software Process Improvement Plans will not be included in the page count limitations for the proposal.

Figure 5-15 Instructions For Site Visit Coordination

- *Facilities and Information.* The items needed by the team at the site visit are mentioned in this section. This information needs to be provided here to set expectations and ensure that the offeror is reasonably well prepared. Note that private interview notes will always remain, source selection sensitive. The SCE team must maintain the confidentiality of interviews or the entire SCE process could be undermined. All data collected during the site visit will become part of the source selection file and will be maintained on all offerors until the contract is closed out.
- *Offeror Exit Briefing.* The PCO will be the final arbiter in determining how the findings will be provided to the offerors. However, any outbriefing must advise the offeror that this may not completely resolve all issues regarding the SCE. It is important for all the offerors to realize that they have the right and must specifically request a

debriefing of the SCE findings. Debriefing the findings achieves two important goals. First, in a Total Quality Management (TQM) approach, the government desires buy-in from the offerors regarding the results, and is seeking to motivate the offerors to improve their capability. Second, the government has the opportunity for direct feedback regarding the conduct of the SCE from the offeror's perspective. This feedback can be used to refine the procedures and instructions for future acquisitions.

- *Page Limitations.* In most RFPs, there is a limit to the number of pages an offeror may use in the preparation of their proposal. The example provided here had such a requirement. Consequently, when the IFPP required submittal of Assessment Recording Forms, Project Profiles, and an SPIP, these document pages were excluded from the proposal page count to ensure they did not detract from the technical content of the proposal subject to the page limitations. This is an administrative detail which will allow page counts to be focused on the technical approach.

This section presented the essential elements needed to accommodate SCE in an RFP. These references should be tailored by the organization to meet the specific needs of the acquisition. The references presented can be changed to accommodate the usage of the SCE findings as a consideration under performance risk or a variation of the specific criterion example presented here.

Placing SCE in the Evaluation Plan

This section provides a sample of the type of information needed to incorporate SCE into the Evaluation Plan, and to assist in the preparation of an evaluation standard for SCE findings.

Evaluation standards must be completed before RFP release. Evaluation standards are written in a detailed manner to promote competition and enhance the discrimination between the offerors.

It is imperative that the SCE team leader be a member or advisor to the Source Selection Evaluation Board (SSEB) to work with SSEB members to apply the evaluation standard to the findings from each of the offerors.

Sample Evaluation
Standard

The example presented in Figure 5-16 is a sample evaluation standard. A detailed evaluation standard is written describing the requirements for the acquisition. This implies that if the requirement is met, the standard is met, and the offeror is scored Green. If the standard is exceeded, the offeror is scored Blue. If the requirement is not met, depending on how near it is to being met, the offeror is scored as Yellow. A Red score denotes serious deficiencies (failure to meet requirements). Application of the color ratings to a standard should be correlated with the appropriate regulations and procurement policies affecting your acquisition.

DESCRIPTION: Software Engineering Capability—The government will evaluate the offeror's organizational software process capability by:

- Performing a Software Capability Evaluation (SCE).
- Evaluating the offeror's program for software process improvement.
- Evaluating the extent to which the offeror's software process supports the goals, objectives, and requirements of the solicitation.

STANDARD- The standard is met when the offeror presents a sound, compliant approach and:

1. The findings from the SCE show that the offeror is strong or acceptable in each of the following key process areas:
 - Software Configuration Management
 - Software Quality Assurance
 - Software Subcontract management
 - Software project tracking and oversight
 - Software project planning
 - Requirements Management
2. The findings from the SCE show that the offeror is strong or acceptable in at least one of the following software process areas:
 - Peer Reviews
 - Intergroup coordination
 - Software product engineering
 - Integrated software management
 - Training program
 - Organization process definition
 - Organization process focus
3. The Software Process Improvement Plan submitted with the offeror's proposal portrays the offeror's current process capability realistically and presents a realistic plan for process improvement. The offeror's plan is consistent with the SCE findings. The SPIP outlines the offeror's plan to achieve higher maturity levels and demonstrates that the offeror understands software process improvement, both technically and in the effort required to increase and sustain higher maturity levels.

Figure 5-16 Streamlined SCE Evaluation Standard

This section presented an example of an evaluation standard which de-emphasizes maturity levels while keeping with the spirit of the CMM. Trained SCE users are able to take this example and tailor it to meet the specific needs of their acquisition. Thus, SCE can contribute effectively to the source selection decision. The findings, provided to the SSEB by the SCE team, are a snapshot of process capability for a specific site at a particular point in time. The way those findings are used by the acquisition organization can be modified through the design of the evaluation standard.

Appendix A SCE Participants in a Source Selection

Figure A-1 shows how a source selection organization may be organized with the incorporation of SCE.

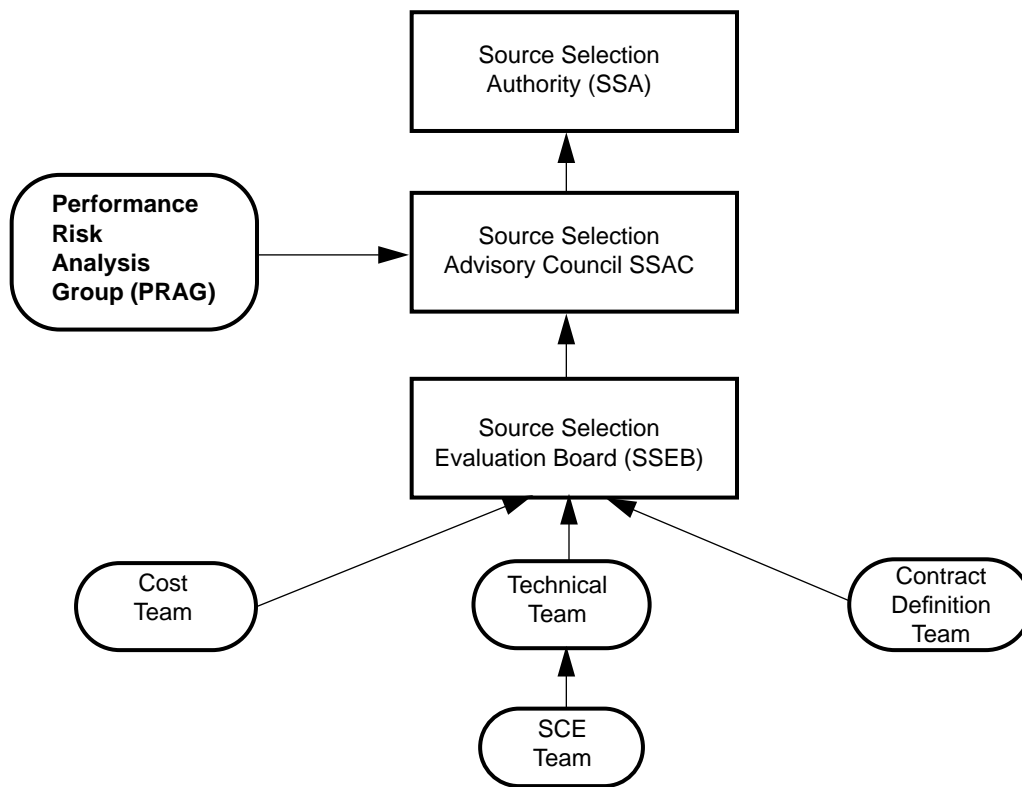

Figure A-1 Sample Source Selection Organization

Note that in this example the cost team and contract definition team are separate. They would be combined when the SSET structure is used.

The following are the principal source selection players who influence the SCE implementation decision, whether it will be used and to what extent the SCE findings will play a role in the source selection decision.

Source Selection Authority (SSA): As the individual ultimately responsible for the conduct of the source selection organization, the SSA is the final arbiter on the use of SCE and approves how the findings will influence the source selection decision and how they will be disclosed to offerors.

Source Selection Advisory Council (SSAC): The SSAC is charged with collecting and analyzing the SSEB's evaluations of each offeror. This is the only group permitted to compare the strengths and weaknesses of the offerors against one another. The SSAC may recommend to the SSA how the SCE findings will be incorporated into the source selection decision at the pre-RFP release briefing.

SSAC Chairperson: This individual is usually the facilitator of the entire process and acts as the SSA's eyes and ears during the course of the source selection. This person is normally the 2-LTR deputy, or at least in the chain-of-command above the program manager. This individual will coordinate all activities with the SSA and facilitate the consensus-building process from within the SSAC.

Performance Risk Analysis Group (PRAG): The PRAG collects data on each offeror's past and present performance on other, similar product acquisitions and from this data determines relevance of effort and assesses the performance risks posed in the offeror's ability to perform if the offeror is selected. SCE findings can be factored into this performance risk assessment. The PRAG does more than assess past performance. It may also assess such things as manufacturing capability, plant capacity, or an offeror's familiarity with the type of work required under the instant solicitation, in an attempt to analyze an offeror's performance risk. The PRAG normally reports directly to the SSA or the SSAC. The PRAG role is fully defined in the AFMC FAR supplement to AFR 70-15 and AFR 70-30. The PRAG needs to be well-educated on what SCE is and what it can provide so that the right information is passed to the SSAC. In these instances, at least one member of the PRAG should be an SCE-trained government individual.

Source Selection Evaluation Board (SSEB): This is the government group that evaluates the offerors' proposals against evaluation standards and section M of the RFP. This group develops the evaluation standards and receives approval to use them from the SSAC and SSA before the issuance of the RFP. The SSEB is usually organized into technical and cost teams representing each of the evaluation areas or technical disciplines important to the award decision. Within each team, each individual brings the technical skills and professional experience necessary to perform a fair and effective evaluation. If the findings of an SCE are being factored into the source selection decision as an Evaluation Criterion, the SCE team leader should be a member of the SSEB. The SSEB prepares, prior to the release of the RFP, an evaluation standard that will incorporate the SCE findings.

SSEB/SSET Chairperson: The SSEB/SSET chairperson coordinates all activities of the SSEB/SSET related to the acquisition. The chairperson will facilitate the incorporation of SCE into the source selection documentation and monitor the various evaluation teams, including the SCE team.

Program Director / Manager: The program director/manager normally orchestrates the acquisition from the vantage point of the SSEB/SSET chairperson, depending upon the nature of the organization and dollar size and criticality of the contract. The SCE team leader will have to work with the program director (if he or she is part of the source selection, otherwise it would be the SSEB/SSET chairperson) during the source selection to perform SCEs as part of the proposal evaluation process and place them in the source selection plan.

A program director of a large program may have a number of contracts under one program that he or she is responsible for. In that capacity, a program manager is typically appointed to each of the contracts and is subordinate to the program director. For a source selection under these circumstances, the program director would more than likely be either the SSAC chairperson or, at the very least, a member of the SSAC. Ultimately, however, the program manager is responsible for

developing the acquisition strategy, getting the requisite approvals to pursue the strategy, implementing the acquisition strategy, and executing the program after contract award.

Procuring Contracting Officer (PCO): The PCO is responsible for all communications with the offerors, and ensuring that the entire source selection process is consistent with the FAR and its internal department- or command-unique regulations. The PCO is also responsible for advising the SSAC on the interpretation of the findings to ensure a consistent and objective award decision. Some organizations have had some of their procurement personnel trained in SCE.

Legal Advisor / Attorney: All source selections require some degree of interaction with the acquisition organization's legal staff. For this reason a JA individual is normally a member of the SSAC. Some organizations have had legal personnel trained in SCE. This training is extremely important because source selections are implemented many different ways throughout the government and acquisition organizations may employ different techniques even within the same government agency.

Software Capability Evaluation (SCE) Team: This is the group of four to six people that will conduct the SCE site visits for the source selection. The SCE team could evaluate the SPIP, Software Development Plan (SDP), and software process-related portions of the proposals. The unique circumstances of each contract will dictate the extent of the contribution the SCE team must make to the source selection (e.g. RFP familiarity, proposal familiarity, and SSEB participation).

SCE Team Leader: This individual will plan, prepare, and execute the SCE. The SCE team leader's responsibilities include advising the SSEB/SSET Chairperson regarding the specific findings of the SCE team and documenting those findings in writing; in addition the team leader may be

required to brief the SCE portion of the technical area. Personnel with previous SCE experience should be assigned to this position.

Contractor SCE Point of Contact: This is the development organization's focal point for an SCE site visit. The SCE team leader will work with this individual to minimize the impact of SCE interviews and documentation gathering on the evaluated organization. The interaction will begin before the site visit to coordinate activities and request documentation or organizational charts. An important point to remember is that all discussions, both planned and unplanned, after the issuance of the RFP must be through the PCO.

Appendix B Acronyms

AFSB	Air Force Science Board
AMC	Army Materiel Command
AMIS	Acquisition Management Information System
BAFO	Best and Final Offer
CAO	Contract Administration Office
CBD	Commerce Business Daily
CDR	Critical Design Review
CMM	Capability Maturity Model
CPAR	Contractor Performance Analysis Report
CPEP	Contractor Performance Analysis Program
CRs	Clarification Requests
CSC	Computer Software Component
CSCI	Computer Software Configuration Item
CSU	Computer Software Unit
DCAA	Defense Contracting Audit Agency
DoD	Department of Defense
DTIC	Defense Technical Information Center
Dem/Val	Demonstration/Validation
DRs	Deficiency Reports
DSMC	Defense Systems Management College
EMD	Engineering Manufacturing Development

ESC	Electronic Systems Center (formally ESD)
FAR	Federal Acquisition Regulation
FCA	Functional Configuration Audit
GAO	General Accounting Office
IFPP	Instructions for Proposal Preparation
IRS	Interface Requirements Specification
JPO	Joint Program Office
JTIDS	Joint Tactical Information Distribution System
KPA	Key Process Area
KSLOC	Thousand Source Lines of Code
LTR	Letter
MCCR	Mission Critical Computer Resources
MMP/CR	Manufacturing Management Production/Capability Review
MQ	Maturity Questionnaire
NAWC	Naval Air Warfare Center
NRAD	NCCOSC (Naval Command, Control, and Ocean Surveillance Center) RDT&E (Research Development Test and Engineering) Division
NTE	Not to Exceed
PCA	Physical Configuration Audit
PCO	Procuring Contracting Officer
PDR	Preliminary Design Review
PEO	Program Executive Officer
PFN	Point For Negotiation

PM	Program Manager
PRAG	Performance Risk Analysis Group
RAI	Request for Additional Information
RFP	Request For Proposal
SCE	Software Capability Evaluation
SCM	Software Configuration Management
SDD	Software Design Document
SDP	Software Development Plan
SDIO	Space Defense Initiative Office
SDR	System Design Review
SEI	Software Engineering Institute
SEPG	Software Engineering Process Group
SOW	Statement of Work
SPIP	Software Process Improvement Plan
SPA	Software Process Assessment
SQA	Software Quality Assurance
SRR	System Requirements Review
SRS	Software Requirements Specification
SSA	Source Selection Authority
SSAC	Source Selection Advisory Council
SSDD	System/Segment Design Document
SSEB	Source Selection Evaluation Board
SSET	Source Selection Evaluation Team
SSEG	Source Selection Evaluation Guide

Appendix B: Acronyms

SSP	Source Selection Plan
USAF	United States Air Force

Appendix C Bibliography

- [ASD 87] Aeronautical Systems Division (ASD), Acquisition Management Pamphlet 800-5, "Software Development Capability/Capacity Review." Department of the Air Force, Air Force Systems Command (AFSC), 10 September 1987.
- [AFSC 90] Air Force Systems Command, AFSC Pamphlet 800-51 "Software Development Capability Assessment (SDCA)," November 1990.
- [AFSB 89] Air Force Studies Board (AFSB) Report, "Adapting Software Development Policies to Modern Technology." Commission on Engineering and Technical Systems, National Research Council, National Academy Press, 1989.
- [Bender 87] Bender, David. *Computer Law*. New York: Matthew Bender, 1987.
- [Bigelow 87] Bigelow, Robert P. *Computer Contracts*. New York: Matthew Bender, 1987.
- [Boehm 91] Boehm, B.W. "Software Risk Management: Principles and Practices," *IEEE Software* 8, 1 (January 1991): 32-41.
- [Bucholz 87] Bucholz, S., and Roth, T. *Creating the High Performance Team*. New York: Wiley, 1987.
- [Carlucci 81] Carlucci, F. C., III, "Improving the Acquisition Process." Memorandum for Secretaries for the Military Departments, et al. Washington, D.C., April 30, 1981.
- [Crosby 88] Crosby, P.B. *Quality is Free*. McGraw-Hill, New York, NY, 1979.
- [Dart 87] Dart, S.; and Ellison, B. *Software Development Environments* (CMU/SEI-87-TR-24, ADA 200542). Pittsburgh, Pa.: Software Engineering Institute, Carnegie Mellon University, 1987.
- [Deep] Deep, Ron, et al. *DSMC Risk Management Guide*. Defense Systems Management College, The Pentagon, Washington, D.C.
- [Deming 86] Deming, W. Edwards. *Out of the Crisis*, MIT Center for Advanced Engineering Study, Cambridge, Ma, 1986.
- [Denton 89] Denton, D. Keith. "Four Steps to Resolving Conflicts." *Quality Progress* 22, 4 (April 1989): 29-33.

- [DoD 88] Department of Defense Standard 2167A (DoD-STD-2167A), "Defense System Software Development." 29 February 1988, superseding DoD-STD-2167.
- [FAR] *Federal Acquisition Regulation*, FAR Supplement 242.70, "Contract Administration." FAR 15.6, "Source Selection." FAR 52.215-1, "Examination of Records by Comptroller General."
- [GAO 86] Technical Risk Assessment—The Status of Current DoD Efforts, General Accounting Office, April 1986.
- [Humphrey 89] Humphrey, Watts S. *Managing the Software Process*. Reading Ma.: Addison-Wesley, 1989.
- [Humphrey 88] Humphrey, Watts S. "Characterizing the Software Process: A Maturity Framework." *IEEE Software* 5, 2 (March 1988): 73-79.
- [Humphrey 87a] Humphrey, Watts. *Characterizing the Software Process: A Maturity Framework* (CMU/SEI-87-TR-11, ADA1828952). Pittsburgh, Pa.: Software Engineering Institute, Carnegie Mellon University, 1987.
- [Humphrey 87b] Humphrey, W.; and Sweet, W. *A Method for Assessing the Software Engineering Capability of Contractors* (CMU/SEI-87-TR-23, ADA187230). Pittsburgh, Pa.: Software Engineering Institute, Carnegie Mellon University, 1987.
- [Juran 88] Juran, J.M. *Juran on Planning for Quality*. New York: Macmillan, 1988.
- [Kelly 91] Kelly, Mark. *The Adventures of a Self-Managing Team*. San Diego: Pfeiffer & Co., 1991.
- [Klein 87] Klein, D.; & Firth, R. *Final Evaluation of MIPS M/500 Final Report of the RISC Insertion Project* (CMU/SEI-87-TR-25, ADA 200611). Pittsburgh, Pa.: Software Engineering Institute, Carnegie Mellon University, 1987.
- [Paulk 93a] Paulk, Mark C., et.al. *Capability Maturity Model For Software, Version 1.1* (CMU/SEI-93-TR-24). Pittsburgh, Pa.: Software Engineering Institute, Carnegie Mellon University, 1993.
- [Paulk 93b] Paulk, Mark C., et.al. *Key Practices of the Capability Maturity Model* (CMU/SEI-93-TR-25). Pittsburgh, Pa.: Software Engineering Institute, Carnegie Mellon University, 1993.

- [SCE 93] Software Capability Evaluation Project. *Software Capablility Evluation Version 2.0 Method Description* (CMU/SEI-93-TR-17). Pittsburgh, Pa.: Software Engineering Institute, Carnegie Mellon University, 1993.
- [USAF 88] United States Air Force. Air Force Regulation 70-15, *Air Force Federal Acquisition Regulation Supplement*, 1990.

Appendix D SCE Implementation Checklist

The following checklist has been extracted from the text of the document.

- | | |
|-----------------------------------|--|
| Acquisition Start | <ul style="list-style-type: none"> <input type="checkbox"/> Develop initial awareness (SPO and PCO organizations) <input type="checkbox"/> Determine applicability to this acquisition <input type="checkbox"/> Review existing SCE policies and procedures <input type="checkbox"/> Review acquisition strategy <input type="checkbox"/> Determine SCE needs for acquisition <input type="checkbox"/> Develop SCE implementation recommendation <input type="checkbox"/> Input to acquisition strategy document <input type="checkbox"/> Champion implementation of SCE on acquisition <input type="checkbox"/> Obtain commitment to use SCE |
| Organize / Select SCE Team | <ul style="list-style-type: none"> <input type="checkbox"/> Review SCE team leader and team member qualification criteria <input type="checkbox"/> Ensure appropriate criteria for team are applied to acquisition <input type="checkbox"/> Attend SCE Overview (for appropriate acquisition personnel) <input type="checkbox"/> Prepare candidate SCE team member list <input type="checkbox"/> Obtain commitment from candidate team member's organization <input type="checkbox"/> Familiarize team with acquisition policy <input type="checkbox"/> Attend SCE training |

Execute Acquisition Start Phase

- Determine SCE placement within source selection documentation
- Prepare recommendation on how SCE findings will be integrated into the acquisition
- Develop Product Profile
- Determine Target Process Capability (TPC)
- Determine disposition of SCE data
- Estimate number of contractor sites to be visited
- Estimate resources and time (manpower, travel, support)
- Determine/schedule/implement preliminary SCE tasks
- Complete CBD announcement input
- Prepare Pre-proposal Conference Briefing
- Insert Acquisition Plan, Source Selection Plan, RFP SCE language
- Request completion of Maturity Questionnaire and project profiles
- Instructions on how to submit material
- Prepare Evaluation Standards

Execute General and Specific Preparation Phases

- Schedule SCE team to meet and execute SCE Method pre-site visit preparation.
- Analyze project profiles
- Select contractor projects
- Identify critical subprocess for all contractors
- Determine key issues for individual contractors
- Develop initial exploratory interview questions and identify initial set of documents for review
- Develop and notify contractor points of contact regarding SCE team logistical requirements (10 working days in advance)
- Arrange site logistics (room, table, chairs, documents, preliminary on-site and interview schedules, computing needs, etc.)

Conduct SCE

- Conduct SCE site data collection
- Conduct in-briefing with on-site contractor
- Analyze organizational and project documentation
- Review and modify agenda and schedule as necessary
- Conduct exploratory interviews
- Request additional documentation
- Validate interview responses
- Draft preliminary findings
- Validate preliminary findings
- Conduct consolidation interviews
- Validate improvement activities
- Develop final findings
- Conduct exit briefing (as prescribed by Procuring Contracting Officer (PCO))

Write / Submit Final Report to Acquisition Organization

- Document conduct of SCE and rationale for findings
- Document effort and resources expended
- Develop lessons learned and provide feedback to improve SCE Method

Assist Acquisition Organization's Use of SCE Findings

- Develop and deliver final SCE results briefing to SSEB (if necessary)
- Consult with SSEB and SSAC as needed (elaborate on SCE findings)
- Assist SSEB in preparing and delivering formal SCE presentation to the SSAC

**Formal
Feedback**

- Conduct SCE findings briefing for winning contractor
- Conduct SCE findings for unsuccessful offerors
- Dispose of SCE data (in accordance with acquisition guidelines)
- Disband SCE team

Appendix E Templates

The figures in this appendix have been extracted from Chapter 5 of this document. The figures show the kind of information about SCE that should be included in acquisition documents.

As part of <Acquisition Agency's> overall effort to improve software quality, cost, and schedule performance, the software process capability of the responding offerors will be a consideration in the source selection decision. <Acquisition Agency> will use the Software Capability Evaluation (SCE) method developed by the Software Engineering Institute (SEI) to evaluate the current software process of responding offerors (see *Capability Maturity Model for Software* (CMU/SEI-93-TR-24, February 1993). Offerors who are determined to be in the competitive range will have their software process capability verified by an SCE team. The SCE team will analyze key process areas (KPAs) through the Defined maturity level and look for a software process improvement program leading to levels of process capability higher than the current capability. A conference will be held at <time> on <date> at <where> to answer any questions.

Figure E-1 Sample CBD Announcement

- 3.0 Source Screening
- 3.1 Screening Criteria. Initial screening of potential offerors was conducted by the publication of a sources-sought synopsis in the Commerce Business Daily on <date>. The synopsis requested that interested offerors provide their qualifications in the following areas:
- a. Software Engineering Capability. Knowledge of software process improvement with a verifiable program for process improvement using the Software Capability Evaluation (SCE) Method developed by the Software Engineering Institute (SEI) to evaluate the current software process of responding offerors (Capability Maturity Model (CMM) (CMU/SEI-93-TR-24, Feb 93)) The offerors who are determined to be in the competitive range after initial government evaluation of proposals is completed will have their software process capability verified by an SCE team. The SCE team will evaluate key process areas (KPAs) through the Defined maturity level and look for a demonstratable software process improvement program leading to levels of process capability higher than the current capability. Do not provide Software Process Assessment (SPA) results.

Figure E-2 SCE as a Screening Criterion in the SSP

6.4 Evaluation Criteria

6.4.1 Assessment Criteria

- a. Soundness of approach
- b. Compliance with requirements

6.4.2 Specific Criteria

- a. Technical Area - This area will evaluate three items (Software Engineering Capability (SEC), Technical (TECH) approach, and Management) represented here in descending order of importance:

1. Software Engineering Capability. The government will evaluate the software process by reviewing the offeror's Software Process Improvement Plan (SPIP) and by using the Software Engineering Institute- (SEI) developed Software Capability Evaluation (SCE) Method. The government will determine the software process capability by investigating the Key Process Area (KPAs) defined in the SEI Technical Report, *Capability Maturity Model for Software* (CMU/SEI-93-TR-24, February 1993). The report contains a description of the Capability Maturity Model (CMM). The government will perform an SCE of each offeror remaining in the competitive range by reviewing current projects at the site proposing on this contract and comparing processes used on those projects in the written proposal/SPIP.

The evaluation will result in a composite, substantiated through individual interviews and reviews of documentation, of the offeror's software process on the government-selected projects. A risk assessment to compare proposed practices to current, validated practices may be performed. The evaluation team will determine findings of the offeror's strengths, weaknesses, and improvement activities in all KPAs through the Defined maturity level. Results of the SCE will not be pass/fail. Identified weaknesses will be provided in writing during subsequent discussions. The offeror will be allowed to respond to the findings with a limited number of pages of text. The on-site evaluators may be separate and distinct from the proposal evaluation team and may include a government contracting representative. All evaluators have been trained in the SCE Method.

Figure E-3 SCE as a Specific Criterion For The SSP

6-3 Present and past performance (Performance risk)

- (1) Present and past performance is a consideration in all acquisition agency source selections. Performance risk is a structured treatment of present and past performance and will be determined for each area. It is a confidence measure that assesses the offeror's present and past work record in order to determine the offeror's ability to perform the proposed effort. Performance risk is assessed by the Performance Risk Analysis Group (PRAG), which should be chaired by a program manager-level (senior) individual and consist of government personnel. Performance evaluation and risk assessment focus on relevant past performance as it relates to the specific criteria. It is the PRAG's responsibility to analyze the data collected; determine its relevance; and to perform an "independent" risk assessment. The results of the SCE will also be factored into the overall performance risk rating assigned by the PRAG. For information on how to establish a PRAG, how it operates, the forms which are used, and how the evaluation is made and reported, refer to the acquisition agency Source Selection Handbook.

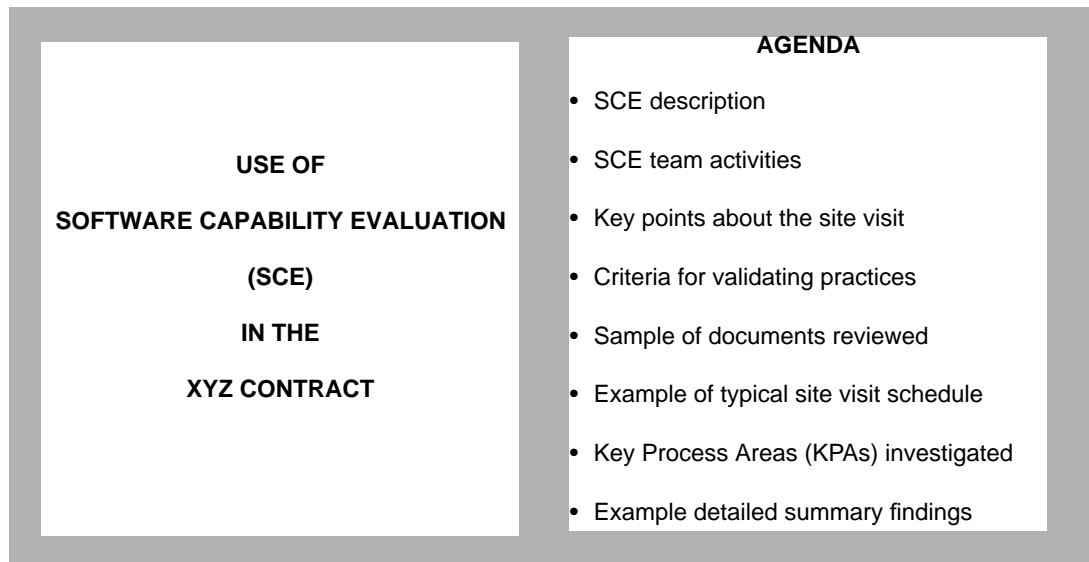
Figure E-4 SCE as part of the PRAG for SSP**Figure E-5 Pre-proposal Conference Title and Agenda Slides**

<p style="text-align: center;">SCE DESCRIPTION</p> <ul style="list-style-type: none">• A method for evaluating the software process of an organization to gain insight into its software development capability.• Five phase evaluation process using the SEI CMM as the basis for evaluation.• Three-day site visit conducted by a four to six-person evaluation team.• Outcome: findings on process capability in terms of software development key process areas (KPAs)—strengths, weaknesses, and improvement activities.• No recommendations will be made.	<p style="text-align: center;">SCE TEAM ACTIVITIES</p> <ul style="list-style-type: none">• Compare RFP product profile with offeror project profiles to select up to four projects for investigation.• Analyze maturity questionnaire responses.• Set expectations (in-brief) and receive process presentation from contractor.• Interview management and key personnel.• Analyze substantiating documentation.• Produce findings through consensus.
<p style="text-align: center;">KEY POINTS ABOUT THE SCE SITE VISIT</p> <ul style="list-style-type: none">• Team decisions made through consensus.• All interviews confidential.• The SCE team may interview an individual more than once during the same visit.• Interview schedule will become dynamic after the first day.• Interview process works down the chain of command.• Working-level development personnel will be interviewed.• Document review occurs throughout process.• SCE team will not make recommendations.	<p style="text-align: center;">CRITERIA FOR VALIDATING PRACTICES</p> <ul style="list-style-type: none">• Written procedure for a practice exists.• Procedure implementing practice must be effective (work for the organization).• Evidence exists showing track record that procedures are followed.• Practice implemented for at least one year (those less than one year may be listed as improvement activities).

Figure E-6 Pre-proposal Conference SCE Method Slides

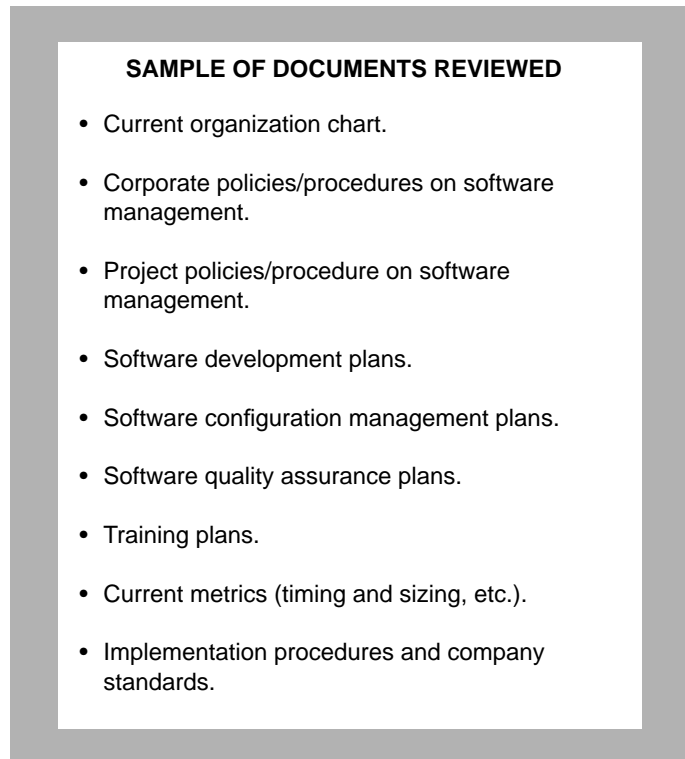

Figure E-7 Pre-proposal Conference Documentation Slide

SAMPLE SITE VISIT SCHEDULE	
DAY 0	
0800-1330	Travel for SCE team
1330-1800	Prepare for site visit
DAY 1	
0800-0830	Contractor welcome/introduction and SCE team's orientation briefing
0830-1030	Contractor software presentation/contractor understanding caucus
1030-1230	Initial review of organizational documents
1230-1330	Lunch
1330-1430	SCE team interviews - senior managers
1430-1600	SCE team interviews - program managers
1600-1730	SCE team interviews - software managers
1730-1800	SCE team caucus and requests documents
DAY 2	
0800-1000	SCE team interviews continued with program managers, software managers
1000-1200	SCE team interviews - managers (engineering, SQA, SCM, test, SEPG)
1200-1300	Lunch
1300-1400	SCE team caucus, request and review documents
DAY 3	
0800-1000	SCE team interviews - key personnel (may include engineering staff)
1000-1200	Review additional documentation
1200-1300	Lunch
1300-1500	Additional documentation review and/or additional SCE team interviews - Consolidation interviews with managers, engineers, and staff
1500-1800	SCE team caucus and preparation of findings
DAY 4	
0800-0900	Final preparation of findings
0900-1000	Exit meeting with offeror
1000-1100	SCE team caucus and wrap-up
1100-1730	Travel for SCE team

Figure E-8 Pre-proposal Conference Site Visit Schedule Slide

Level	Characteristic	Key Process Area
Optimizing (5)	<ul style="list-style-type: none"> Continuous process improvement capability 	<ul style="list-style-type: none"> Process change management Technology innovation Defect prevention
Managed (4)	<ul style="list-style-type: none"> Product quality planning and tracking of measured software process 	<ul style="list-style-type: none"> Process measurement and analysis Quality management
Defined (3)	<ul style="list-style-type: none"> Life cycle process defined and institutionalized to provide product quality control 	<ul style="list-style-type: none"> Peer Reviews Intergroup coordination Software product engineering Integrated software management Training program Organization process definition Organization process focus
Repeatable (2)	<ul style="list-style-type: none"> Management oversight and tracking of project Stable planning 	<ul style="list-style-type: none"> Software configuration management Software quality assurance Software subcontract management Software project tracking and oversight Software project planning Requirements management
Initial (1)	<ul style="list-style-type: none"> Ad hoc (unpredictable, chaotic) 	

Figure E-9 Pre-proposal Conference CMM Slide

SAMPLE DETAILED FINDING SQA KPA	EXAMPLE SUMMARY FINDING
<p>Strengths</p> <ul style="list-style-type: none">• Independent reporting chain• Highly visible• Insuring software engineering standards compliance• Management commitment - strong staff <p>Weaknesses</p> <ul style="list-style-type: none">• Inconsistent auditing• Ineffective use of resources <p>Improvement Activities</p> <ul style="list-style-type: none">• Establishing procedures for consistent auditing	<p>Strong</p> <ul style="list-style-type: none">• Software Quality Assurance (SQA) <p>Acceptable</p> <ul style="list-style-type: none">• Software Project Planning• Software Configuration Management• Requirement Management <p>Weak</p> <ul style="list-style-type: none">• Software Subcontract Management• Organization Process Definition• Training Program• Peer Reviews

Figure E-10 Pre-Proposal Conference Sample Findings Slides

- B. Evaluation Criteria
 - 1.0 Introduction
 - 2.0 Basis for Contract Award
 - 3.0 General Considerations
 - 4.0 Assessment Criteria
 - 4.1 Specific Criteria
 - 4.1.1 Technical Area
 - a. Technical Area - This area will evaluate three items (SEC, TECH approach and Management) represented here in descending order of importance:
 - 1. Software Engineering Capability. The government will evaluate the software process by reviewing the offeror's Software Process Improvement Plan (SPIP) and by using the Software Engineering Institute (SEI)-developed Software Capability Evaluation (SCE). The government will determine the software process capability by investigating the Key Process Area (KPAs) defined in the SEI Technical Report, *Capability Maturity Model for Software* (CMU/SEI-93-TR-24). The report contains a description of the Capability Maturity Model (CMM) and the SEI-defined maturity levels. The government will perform an SCE of each offeror remaining in the competitive range by reviewing current projects at the site proposing on this contract and comparing methods/processes used on those projects in the written proposal/SPIP.

The evaluation will result in an organizational composite, substantiated through individual interviews and reviews of documentation, of the offeror's software process activities on the government-selected projects. A risk assessment to compare proposed practices to current, validated practices may be performed. The evaluation team will determine findings of the offeror's strengths, weaknesses, and improvement activities in all KPAs through the Defined maturity level. Results of the SCE will not be pass/fail. Identified weaknesses will be provided in writing during subsequent discussions. The offeror will be allowed to respond to the findings with a limited number of pages of text. The on-site evaluators may be separate and distinct from the proposal evaluation team and may include a government contracting representative. All evaluators have been trained in the SCE Method.
- 4.2 Cost/Price Area...

Figure E-11 General RFP Language To Include SCE (RFP Section M)

3.0 **Volume X - Technical Proposal**

3.1 **General Instructions** The Technical Proposal shall consist of the Executive Summary and <n> sections...

3.2 **Executive Summary...**

3.3 **Specific Instructions...**

3.3.1 **Section I - Software Engineering Capability.** The offeror will provide the following information to assist the government's preparation for the Software Capability Evaluation of each offeror:

a. The offeror will complete the SEI Maturity Questionnaire (MQ) (current version) using the Assessment Recording Form for eight current projects at the site proposing on this solicitation (a project is acceptable only if it has been completed in the last year). The offeror should select those projects that best match the engineering requirements of this contract. For offerors with fewer than eight current projects at the proposing site, submit MQ responses for as many projects as are available. For each "yes" response, please note on the comment line the mechanism or documentation justifying the response. The MQ can be found in Atch XXX of the IFPP. The completed Assessment Recording Forms will be submitted with the proposal. For all responses, please note at the start of the comment line the degree of implementation of each practice using a letter identifier from the following legend:

A - Not implemented at this time.
B - Not implemented at this time, but desired.
C - Currently planning to implement. See improvement plan.
D - In the process of implementing.
E - Implemented with less than a year's experience.
F - Implemented on a project-by-project basis.
G - Implemented organizationally.
H - Not appropriate for our organization.

Figure E-12 Instructions For Completing Assessment Recording Forms

3.31 (continued)

- b. For each project, the offeror will complete a Project Profile, attach it to the respective Assessment Recording Form, and submit it with the proposal. The Project Profile template can also be found in Atch XXX of the IFPP. This document shall be no greater than one page per project.

Figure E-13 Instructions For Completing Project Profiles

3.31 (continued)

- c. The offeror will submit the proposing site's Software Process Improvement Plan (SPIP), in the format of their choosing, with the proposal. The document will be no more than 15 pages. The SPIP should communicate the offeror's current software process capability as well as their desired maturity level, specific planned improvements, dedicated resources, effort estimates, and a time phasing of those improvements to bring the offeror's software process capability to the organization's desired maturity level.

Figure E-14 Instructions For Submitting the Software Process Improvement Plan (SPIP)

3.31 (continued)

- d. After the proposal is received, the government will coordinate a site visit with those offerors remaining in the competitive range to conduct the Software Capability Evaluation (SCE) at the offeror's location. The offeror will provide, with your proposal, a point of contact and phone number at the offeror's site for the SCE team leader to coordinate all SCE activities. The government will also communicate details about the site visit during the coordination process. The offeror will be notified of the projects to be examined approximately five working days prior to the site visit. The site visit dates selected by the government are not open for discussion.
- e. If a site visit is conducted with your firm, the SCE team will need a closed meeting room capable of accommodating at least eight people. The offeror should have a copy of the organization's software standards, procedures and/or operating instructions, and organizational charts for the projects being reviewed in the meeting room when the SCE team arrives. All interviews conducted as part of the SCE will be done in private, one individual at a time.
- f. The Assessment Recording Forms, Project Profiles, and Software Process Improvement Plans will not be included in the page count limitations for the proposal.

Figure E-15 Instructions For Site Visit Coordination

DESCRIPTION: Software Engineering Capability—The government will evaluate the offeror's organizational software process capability by:

- Performing a Software Capability Evaluation (SCE).
- Evaluating the offeror's program for software process improvement.
- Evaluating the extent to which the offeror's software process supports the goals, objectives, and requirements of the solicitation.

STANDARD- The standard is met when the offeror presents a sound, compliant approach and:

1. The findings from the SCE show that the offeror is strong or acceptable in each of the following key process areas:
 - Software Configuration Management
 - Software Quality Assurance
 - Software Subcontract management
 - Software project tracking and oversight
 - Software project planning
 - Requirements Management
2. The findings from the SCE show that the offeror is strong or acceptable in at least one of the following software process areas:
 - Peer Reviews
 - Intergroup coordination
 - Software product engineering
 - Integrated software management
 - Training program
 - Organization process definition
 - Organization process focus
3. The Software Process Improvement Plan submitted with the offeror's proposal portrays the offeror's current process capability realistically and presents a realistic plan for process improvement. The offeror's plan is consistent with the SCE findings. The SPIP outlines the offeror's plan to achieve higher maturity levels and demonstrates that the offeror understands software process improvement, both technically and in the effort required to increase and sustain higher maturity levels.

Figure E-16 Streamlined SCE Evaluation Standard

Appendix F Pre-Proposal Conference Slides

The purpose of the pre-proposal conference is to explain the SCE process and solicit feedback from the prospective offerors. The information on the slides in this appendix is identical to the information in the examples shown in Chapter 5 of slides that may be used in a pre-proposal conference (see pages 5-91 to 5-99).

In this appendix the slides have been enlarged so that they may be used directly in a presentation.

Use of Software Capability Evaluation (SCE) in the XYZ Contract

<date>

<company name>

Agenda

SCE description

SCE team activities

Key points about the site visit

Criteria for validating practices

Sample of documents reviewed

Example of typical site visit schedule

Key process areas (KPAs) investigated

Example detailed summary findings

SCE Description

A method for evaluating the software process of an organization to gain insight into its software development capability.

Five-phase evaluation process using the SEI CMM as the basis for evaluation

Three-day site visit conducted by a four- to six-person evaluation team

Outcome: findings on process capability in terms of software development key process areas (KPAs)—strengths, weaknesses, and improvement activities.

No recommendations will be made.

SCE Team Activities

Compare RFP product profile with offeror project profiles to select up to four projects for investigation.

Analyze maturity questionnaire responses.

Set expectations (in-brief) and receive process presentation from contractor.

Interview management and key personnel.

Analyze substantiating documentation.

Produce findings through consensus.

Key Points About the SCE Site Visit

Team decisions made through consensus.

All interviews confidential.

The SCE team may interview an individual more than once during the same visit.

Interview schedule will become dynamic after the first day.

Interview process works down the chain of command.

Working-level development personnel will be interviewed.

Document review occurs throughout process.

SCE team will not make recommendations.

Criteria for Validating Practices

Written procedure for a practice exists.

Procedure implementing practice must be effective (work for the organization).

Evidence exists showing track record that procedures are followed.

Practice implemented for at least one year (those less than one year may be listed as improvement activities).

Sample of Documents Reviewed

Current organization chart.

Corporate policies/procedures on software management.

Project policy/procedure on software management.

Software development plans.

Software configuration management plans.

Software quality assurance plans.

Training plans.

Current metrics (timing and sizing, etc.).

Implementation procedures and company standards.

Sample Site Visit Schedule - Day 0

0800-1330 **Travel for SCE team**

1330-1800 **Prepare for site visit**

Sample Site Visit Schedule -Day 1

0800-0830	Contractor welcome/introduction and SCE team's orientation briefing
0830-1030	Contractor software presentation/contractor understanding caucus
1030-1230	Initial review of organizational documents
1230-1330	Lunch
1330-1430	SCE team interviews - senior managers
1430-1600	SCE team interviews - program managers
1600-1730	SCE team interviews - software managers
1730-1800	SCE team caucus and requests documents

Sample Site Visit Schedule -Day 2

- | | |
|------------------|---|
| 0800-1000 | SCE team interviews continued with program managers, software managers |
| 1000-1200 | SCE team interviews - managers (engineering, SQA, SCM, test, SEPG) |
| 1200-1300 | Lunch |
| 1300-1400 | SCE team caucus, request and review documents |

Sample Site Visit Schedule - Day 3

- | | |
|------------------|---|
| 0800-1000 | SCE team interviews - key personnel (may include engineering staff) |
| 1000-1200 | Review additional documentation |
| 1200-1300 | Lunch |
| 1300-1500 | Additional documentation review and/or additional SCE team interviews - consolidation interviews with managers, engineers, and staff |
| 1500-1800 | SCE team caucus and preparation of findings |

Sample Site Visit Schedule -Day 4

- 0800-0900** Final preparation of findings
- 0900-1000** Exit meeting with offeror
- 1000-1100** SCE team caucus and wrap-up
- 1100-1730** Travel for SCE team

The Capability Maturity Model

Level	Characteristic	Key Process Area
Optimizing (5)	<ul style="list-style-type: none"> • Continuous process improvement capability 	<ul style="list-style-type: none"> • Process change management • Technology innovation • Defect prevention
Managed (4)	<ul style="list-style-type: none"> • Product quality planning and tracking of measured software process 	<ul style="list-style-type: none"> • Process measurement and analysis • Quality management
Defined (3)	<ul style="list-style-type: none"> • Life cycle process defined and institutionalized to provide product quality control 	<ul style="list-style-type: none"> • Peer Reviews • Inter group coordination • Software product engineering • Integrated software management • Training program • Organization process definition • Organization process focus
Repeatable (2)	<ul style="list-style-type: none"> • Management oversight and tracking of project • Stable planning 	<ul style="list-style-type: none"> • Software configuration management • Software quality assurance • Software subcontract management • Software project tracking and oversight • Software project planning • Requirements management
Initial (1)	<ul style="list-style-type: none"> • Ad hoc (unpredictable, chaotic) 	

Sample Detailed Finding: SQA KPA

Strengths

- Independent reporting chain
- Highly visible
- Insuring software engineering standards compliance
- Management commitment - strong staff

Weaknesses

- Inconsistent auditing
- Ineffective use of resources

Improvement Activities

- Establishing procedures for consistent auditing

Example Summary Finding

Strong

- **Software Quality Assurance (SQA)**

Acceptable

- **Software Project Planning**
- **Software Configuration Management**
- **Requirement Management**

Weak

- **Software Subcontract Management**
- **Organization Process Definition**
- **Training Program**
- **Peer Reviews**

REPORT DOCUMENTATION PAGE

1a. REPORT SECURITY CLASSIFICATION Unclassified		1b. RESTRICTIVE MARKINGS None														
2a. SECURITY CLASSIFICATION AUTHORITY N/A		3. DISTRIBUTION/AVAILABILITY OF REPORT Approved for Public Release Distribution Unlimited														
2b. DECLASSIFICATION/DOWNGRADING SCHEDULE N/A																
4. PERFORMING ORGANIZATION REPORT NUMBER(S) CMU/SEI-94-TR-5		5. MONITORING ORGANIZATION REPORT NUMBER(S) ESC-TR-94-005														
6a. NAME OF PERFORMING ORGANIZATION Software Engineering Institute	6b. OFFICE SYMBOL (if applicable) SEI	7a. NAME OF MONITORING ORGANIZATION SEI Joint Program Office														
6c. ADDRESS (city, state, and zip code) Carnegie Mellon University Pittsburgh PA 15213		7b. ADDRESS (city, state, and zip code) HQ ESC/ENS 5 Eglin Street Hanscom AFB, MA 01731-2116														
8a. NAME OFFUNDING/SPONSORING ORGANIZATION SEI Joint Program Office	8b. OFFICE SYMBOL (if applicable) ESC/ENS	9. PROCUREMENT INSTRUMENT IDENTIFICATION NUMBER F1962890C0003														
8c. ADDRESS (city, state, and zip code) Carnegie Mellon University Pittsburgh PA 15213		10. SOURCE OF FUNDING NOS. <table border="1" style="width: 100%; border-collapse: collapse; margin-top: 5px;"> <tr> <td style="width: 25%;">PROGRAM ELEMENT NO</td> <td style="width: 25%;">PROJECT NO.</td> <td style="width: 25%;">TASK NO</td> <td style="width: 25%;">WORK UNIT NO.</td> </tr> <tr> <td>63756E</td> <td>N/A</td> <td>N/A</td> <td>N/A</td> </tr> </table>			PROGRAM ELEMENT NO	PROJECT NO.	TASK NO	WORK UNIT NO.	63756E	N/A	N/A	N/A				
PROGRAM ELEMENT NO	PROJECT NO.	TASK NO	WORK UNIT NO.													
63756E	N/A	N/A	N/A													
11. TITLE (Include Security Classification) Software Capability Evaluation (SCE) Version 2.0 Implementation Guide																
12. PERSONAL AUTHOR(S) CMM-Based Appraisal Project																
13a. TYPE OF REPORT Final	13b. TIME COVERED FROM TO	14. DATE OF REPORT (year, month, day) February 1994	15. PAGE COUNT													
16. SUPPLEMENTARY NOTATION																
17. COSATI CODES <table border="1" style="width: 100%; border-collapse: collapse; margin-top: 5px;"> <thead> <tr> <th style="width: 33%;">FIELD</th> <th style="width: 33%;">GROUP</th> <th style="width: 33%;">SUB. GR.</th> </tr> </thead> <tbody> <tr><td> </td><td> </td><td> </td></tr> <tr><td> </td><td> </td><td> </td></tr> <tr><td> </td><td> </td><td> </td></tr> </tbody> </table>			FIELD	GROUP	SUB. GR.										18. SUBJECT TERMS (continue on reverse of necessary and identify by block number)	
FIELD	GROUP	SUB. GR.														
19. ABSTRACT (continue on reverse if necessary and identify by block number) <p>The ability to quantify risk is essential to the process of budgeting and scheduling. During the process of hiring to complete specified tasks, customers must be able to verify contractor estimates and to make sound judgments on the risks of cost overruns and time delays. The following two questions are central to this paper: Do developers with little experience over-estimate or under-estimate the complexity of the task because of their past experience, the assumptions they make, the models they select, and how they define the model parameters? What are the sources of risk associated with project cost estimation? How can such risk be quantified? To address these questions, this paper</p> <p style="text-align: right;">(please turn over)</p>																
20. DISTRIBUTION/AVAILABILITY OF ABSTRACT UNCLASSIFIED/UNLIMITED <input checked="" type="checkbox"/> SAME AS RPT <input type="checkbox"/> DTIC USERS <input checked="" type="checkbox"/>			21. ABSTRACT SECURITY CLASSIFICATION Unclassified, Unlimited Distribution													
22a. NAME OF RESPONSIBLE INDIVIDUAL Thomas R. Miller, Lt Col, USAF		22b. TELEPHONE NUMBER (include area code) (412) 268-7631	22c. OFFICE SYMBOL ESC/ENS (SEI)													

proposed a systematic acquisition process that is aimed at assessing and managing the risks of cost overruns and time delays associated with software development.

The proposed acquisition process, which is composed of four phases (listed below), is grounded on the following three basic premises: a) Any single-value estimate of cost or completion time is inadequate to capture and represent the variability and uncertainty associated with cost and schedule. Probabilistic quantification is advocated, using, in this paper, the fractile method and triangular distribution. b) The common expected value when used as a measure of risk, is inadequate; further, if used as the sole measure of risk, it may lead to inaccurate results. The conditional expected value of risk of extreme events is adopted to supplement and complement the common unconditional expected value. c) Probing the sources of risks and uncertainties associated with cost overruns and time delays in software development is essential for the ultimate management of technical and nontechnical risks. The Taxonomy-Based Questionnaire developed by the Software Engineering Institute is adopted.

These basic premises have led to the development of the following four phases in the proposed acquisition process: Phase I, constructing the probability density functions; Phase II, probing the sources of risks and uncertainties; Phase III, analyzing and regarding the likelihood of technical and non-technical risks; and Phase IV, drawing conclusions on the basis of the accumulated evidence and ultimately selecting the contractors most likely to complete the project without major cost overruns or time delays. The three example problems are presented to demonstrate the construction of the probability density functions in Phase I and to explain in a more general way the effort involved in Phases II through IV.